

Characterised control valve with thermal energy meter, sensor-operated flow or power control, power and energy monitoring function, 2-way, internal and external thread, PN 25

- Nominal voltage AC/DC 24 V
- Control modulating, communicative, hybrid
- For closed water systems
- For modulating control of air-handling and heating systems on the water side
- Ethernet 10/100 Mbit/s, TCP/IP, integrated web server
- Communication via BACnet, Modbus, Belimo MP-Bus or conventional control
- PoE (Power over Ethernet) Power supply possible
- Conversion of sensor signals
- Glycol monitoring
- Power control, flow control, position control and differential pressure control

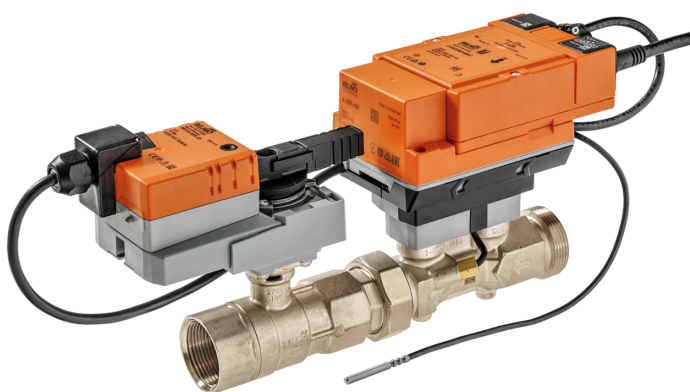

Picture may differ from product



Type Overview

Type	DN	Rp ["]	G ["]	V'nom [l/s]	V'nom [l/min]	V'nom [m³/h]	Kvs theor. [m³/h]	PN
EV015R2+BAC	15	1/2	3/4	0.42	25	1.5	3.2	25
EV020R2+BAC	20	3/4	1	0.69	41.7	2.5	5.3	25
EV025R2+BAC	25	1	1 1/4	0.97	58.3	3.5	8.8	25
EV032R2+BAC	32	1 1/4	1 1/2	1.67	100	6	14.1	25
EV040R2+BAC	40	1 1/2	2	2.78	166.7	10	19.2	25
EV050R2+BAC	50	2	2 1/2	4.17	250	15	30.4	25

Kvs theor.: theoretical Kvs value for pressure drop calculation

Structure

**Components** The Belimo Energy Valve consists of a characterised control valve, an actuator and a thermal energy meter with a logic and a sensor module.

The logic module provides the power supply, the communication interface and the NFC connection of the energy meter. All relevant data are measured and recorded in the sensor module.

This modular design of the energy meter means that the logic module can remain in the system if the sensor module is replaced.

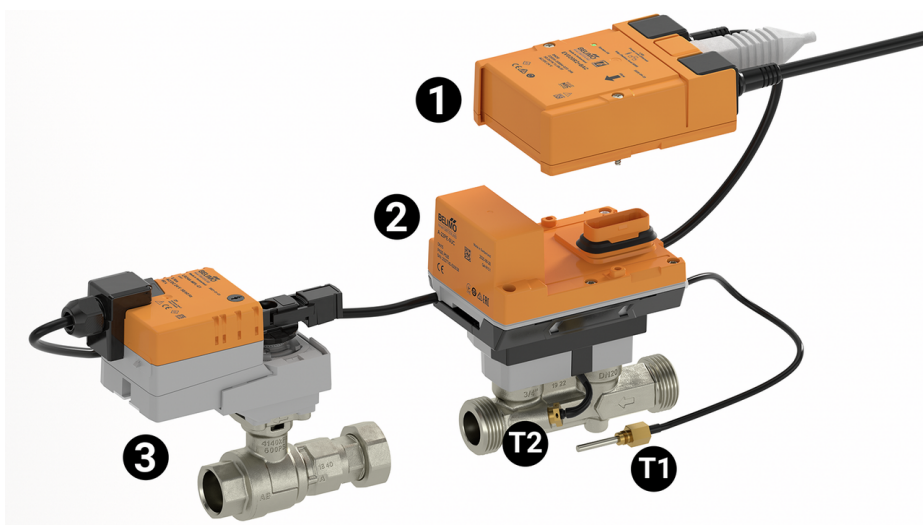

- External temperature sensor T1
- Integrated temperature sensor T2
- Logic module 1
- Sensor module 2
- Characterised control valve with actuator 3

Technical data

Electrical data    Nominal voltage    AC/DC 24 V

**Technical data**

<b>Electrical data</b>	Nominal voltage frequency	50/60 Hz
	Nominal voltage range	AC 19.2...28.8 V / DC 21.6...28.8 V
	Power consumption in operation	4 W (DN 15, 20, 25) 5 W (DN 32, 40, 50)
	Power consumption in rest position	3.7 W (DN 15, 20, 25) 3.9 W (DN 32, 40, 50)
	Power consumption for wire sizing	6.5 VA (DN 15, 20, 25) 7.5 VA (DN 32, 40, 50)
	Connection supply / control	Cable 1 m, 6x 0.75 mm <sup>2</sup>
	Connection Ethernet	RJ45 socket
	Power over Ethernet PoE	DC 37...57 V 11 W (PD13W) IEEE 802.3af/at, Type 1, Class 3
	Conductors, cables	Power supply AC/DC 24 V: cable length <100 m, no shielding or twisting required Power supply PoE: shielded cables recommended
	Cable length	1 m
	<b>Data bus communication</b>	Communicative control
Number of nodes		BACnet / Modbus see interface description MP-Bus max. 8
<b>Functional data</b>	Operating range Y	2...10 V
	Operating range Y variable	0.5...10 V
	Input impedance	100 kΩ
	Position feedback U	2...10 V
	Position feedback U note	Max. 1 mA
	Position feedback U variable	0...10 V 0.5...10 V
	Sound power level motor	35 dB(A) dB(A) (DN 15, 20, 25, 32, 40) 45 dB(A) dB(A) (DN 50)
	V'max adjustable	25...100% of V'nom
	Control accuracy	±5% (of 25...100% V'nom)
	Control accuracy note	±10% (of 25...100% V'nom) @ Glycol 0...60% vol.
	Min. controllable flow	1% of V'nom
	Configuration	via NFC, Belimo Assistant 2 via integrated web server
	Fluid	Water, water with glycol up to max. 60% vol.
	Fluid temperature	-10...120°C [14...248°F]
	Fluid temperature note	At a fluid temperature of -10...2°C, a stem heater or a valve neck extension is recommended.
	Close-off pressure Δps	1400 kPa
	Differential pressure Δpmax	350 kPa
	Differential pressure note	200 kPa for low-noise operation
	Flow characteristic	equal percentage (VDI/VDE 2173), optimised in the opening range
	Flow characteristic note	switchable to linear (VDI/VDE 2173)
Leakage rate	air-bubble tight, leakage rate A (EN 12266-1)	
Pipe connection	Internal and external thread	

**Technical data**

<b>Functional data</b>	Installation orientation	upright to horizontal (in relation to the spindle)
	Servicing	maintenance-free
	Manual override	with push-button, can be locked
<b>Measuring data</b>	Measured values	Flow Fluid temperature supply Fluid temperature return
	Temperature sensor	Pt1000 - EN 60751, 2-wire technology, inseparably connected Cable length external sensor T1: 3 m T2 integrated in flow sensor
<b>Temperature measurement</b>	Measuring accuracy absolute temperature	Temperature probe (probe only – individually compensated): $\pm (0.1 + 0.0017  T ) \text{ }^\circ\text{C}$ (corresponds to Pt1000 EN60751 Class AA) Calculator + temperature probe: $\pm (0.15 + 0.002  T ) \text{ }^\circ\text{C}$
	Measuring accuracy differential temperature	Calculator + temperature probe: $\pm 0.17\text{K} @ \Delta T = 5\text{K}$ $\pm 0.22 \text{ K} @ \Delta T = 10 \text{ K}$ $\pm 0.32 \text{ K} @ \Delta T = 20 \text{ K}$
<b>Flow measurement</b>	Measuring principle	Ultrasonic flow measurement
	Measuring accuracy flow	$\pm 2\%$ , according to class 2 EN 1434, glycol 0% vol.
	Measuring accuracy flow note	@ 15...120°C Inlet section $\geq 0x \text{ DN}$ (EN 1434-4:2022) $\pm 5\%$ (of 20...100% V'nom) @ glycol 0...60% vol.
	Min. flow measurement	0.2% of V'nom
<b>Glycol monitoring</b>	Measurement display glycol	0...60%
	Measuring accuracy glycol monitoring	$\pm 4\%$
<b>Safety data</b>	Protection class IEC/EN	III, Protective Extra-Low Voltage (PELV)
	Degree of protection IEC/EN	IP54 Logic module: IP54 (with grommet A-22PEM-A04) Sensor module: IP65
	Pressure equipment directive	CE according to 2014/68/EU
	EMC	CE according to 2014/30/EU
	Certification IEC/EN	IEC/EN 60730-1:11 and IEC/EN 60730-2-15:10
	Quality Standard	ISO 9001
	Type of action	Type 1
	Rated impulse voltage supply / control	0.8 kV
	Pollution degree	3
	Ambient humidity	Max. 95% RH, non-condensing
	Ambient temperature	-30...50°C [-22...122°F]
	Storage temperature	-40...80°C [-40...176°F]
	<b>Materials</b>	Valve body
Body finish		nickel-plated
Flow measuring pipe		Nickel-plated brass body
Closing element		Stainless steel
Spindle		Stainless steel
Spindle seal		EPDM O-ring
Immersion sleeve		Stainless steel

Safety notes



- This device has been designed for use in stationary heating, ventilation and air-conditioning systems and must not be used outside the specified field of application, especially in aircraft or in any other airborne means of transport.
- Outdoor application: only possible in case that no (sea) water, snow, ice, insolation or aggressive gases interfere directly with the device and that it is ensured that the ambient conditions remain within the thresholds according to the data sheet at any time.
- Only authorised specialists may carry out installation. All applicable legal or institutional installation regulations must be complied with during installation.
- The device contains electrical and electronic components and must not be disposed of as household refuse. All locally valid regulations and requirements must be observed.

Product features

**Operating mode** The HVAC performance device is comprised of four components: characterised control valve (CCV), measuring pipe with flow sensor, temperature sensors and the actuator itself. The adjusted maximum flow ( $V_{max}$ ) is assigned to the maximum control signal DDC (typically 10 V / 100%). Alternatively, the control signal DDC can be assigned to the valve opening angle or to the power required on the heat exchanger (see power control). The HVAC performance device can be controlled via communicative or analogue signals. The fluid is detected by the sensor in the measuring pipe and is applied as the flow value. The measured value is balanced with the setpoint. The actuator corrects the deviation by changing the valve position. The angle of rotation  $\alpha$  varies according to the differential pressure through the control element (see flow curves).

**Calibration certificate** A calibration certificate is available in the Belimo Cloud for each thermal energy meter. If required, this can be downloaded as a PDF with Belimo Assistant 2 or via the Belimo Cloud frontend.

**Power calculation** The thermal energy meter calculates the current thermal power based on the current flow rate and the measured temperature difference.

**Energy consumption** The energy consumption data can be read out as follows:

- Bus
- Cloud API
- Belimo Cloud Account of the device owner
- Belimo Assistant 2
- Integrated web server

**PoE (Power over Ethernet)** If necessary, the Energy Valve can be supplied with power via the Ethernet cable. This function can be enabled via Belimo Assistant 2.  
DC 24 V (max. 8 W) is available at wires 1 and 2 for power supply of external devices (e.g. actuator or active sensor).  
Caution: PoE may only be enabled if an external device is connected to wires 1 and 2 or if wires 1 and 2 are insulated!

**Spare parts** Sensor module of the thermal energy meter consisting of:

- 1 x sensor module including integrated temperature sensor T2 and external temperature sensor T1

Flow rate curves

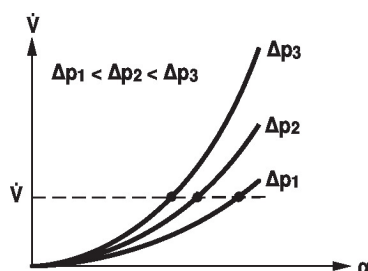

Product features

**Transmission behaviour HE** Heat exchanger transmission behaviour

Depending on the construction, temperature spread, fluid characteristics and hydronic circuit, the power  $Q$  is not proportional to the water volumetric flow  $V'$  (Curve 1). With the classical type of temperature control, an attempt is made to maintain the control signal  $Y$  proportional to the power  $Q$  (Curve 2). This is achieved by means of an equal-percentage flow characteristic (Curve 3).

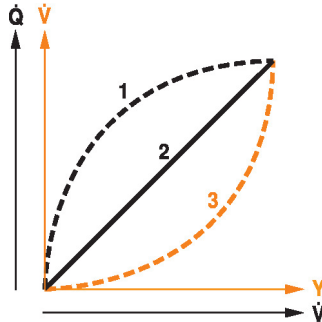

**Power control** Alternatively, the control signal DDC can be assigned to the output power required at the heat exchanger.

Depending on the water temperature and air conditions, the Energy Valve ensures the amount of water  $V'$  required to achieve the desired power.

Maximum controllable power on heat exchanger in power control mode:

<b>DN 15</b>	<b>90 kW</b>
<b>DN 20</b>	<b>150 kW</b>
<b>DN 25</b>	<b>210 kW</b>
<b>DN 32</b>	<b>350 kW</b>
<b>DN 40</b>	<b>590 kW</b>
<b>DN 50</b>	<b>880 kW</b>

**Control characteristics** The specially configured control parameters in connection with the precise velocity sensor ensure a stable quality of control. They are, however, not suitable for rapid control processes, i.e. for domestic water control.

Power control

$Q'_{nom}$  is the maximum possible power output on the heat exchanger.

$Q'_{max}$  is the maximum power output on the heat exchanger which has been set with the highest control signal DDC.  $Q'_{max}$  can be set between 1% and 100% of  $Q'_{nom}$ .

$Q'_{min}$  0% (non-variable).

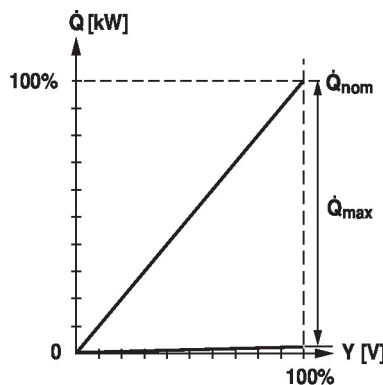

## Product features

## Flow control

$V_{nom}$  is the maximum possible flow.

$V_{max}$  is the maximum flow rate which has been set with the highest control signal DDC.

$V_{max}$  can be set between 25% and 100% of  $V_{nom}$ .

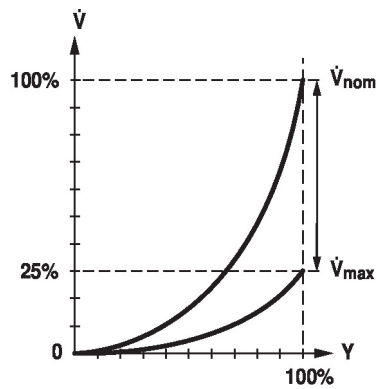

## Position control

In this setting, the control signal is assigned to the opening angle of the valve (e.g.  $Y = 10 \text{ V} \alpha = 90^\circ$ ).

The result is a pressure-dependent operation similar to that of a conventional valve.

Running time of the motor in this mode is 90 s for  $90^\circ$ .

Product features

**Differential pressure control**

In addition to power control, flow control and position control, the Energy Valve can be used to control the differential pressure between two measuring points of a differential pressure sensor (not included).

The following differential pressure sensors can be used:

- Belimo differential pressure sensor 22WDP-11..
- Belimo differential pressure sensor 22PDP-18..

The specifications listed in the sensor data sheet must be observed.

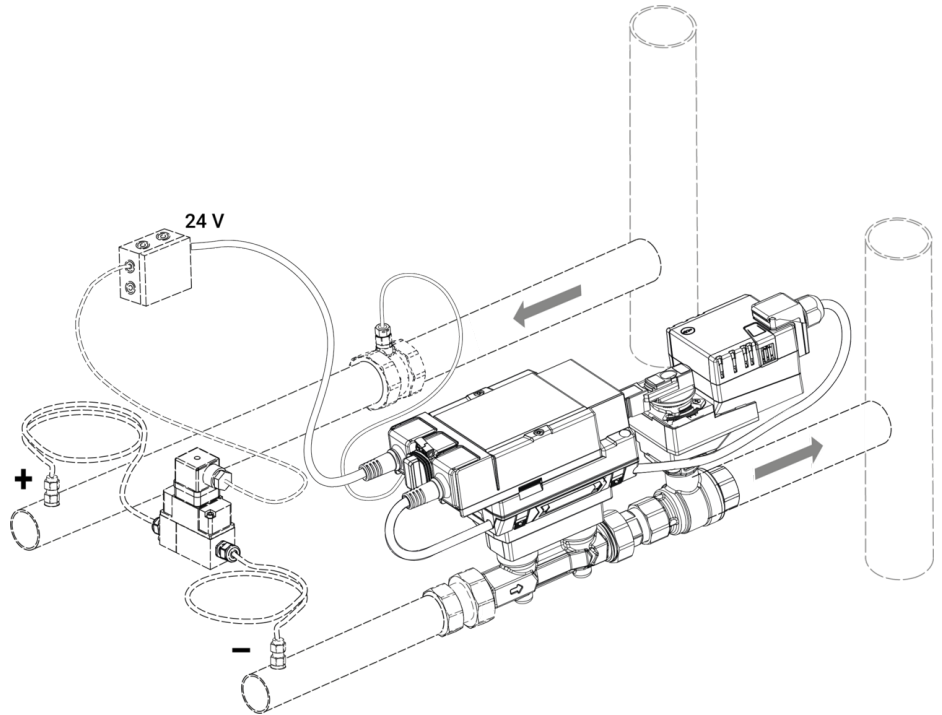

Energy Valve with accessories  
 Differential pressure sensor 22WDP-11..  
 Pipe connector ZREV..F  
 T-piece with thermowell A-22PE-A0..

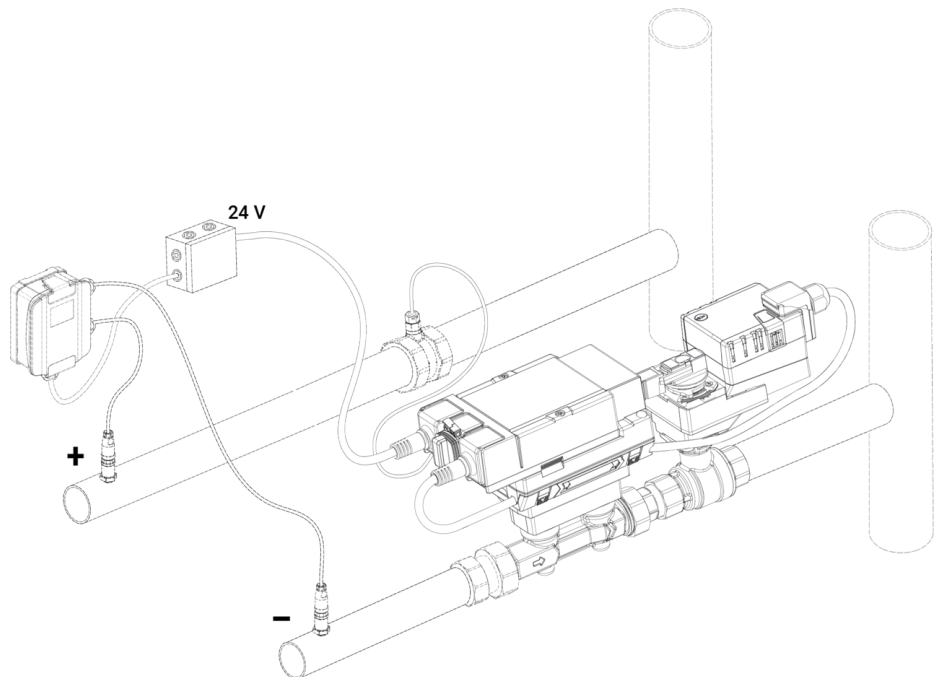

Energy Valve with accessories  
 Differential pressure sensor 22PDP-18..  
 Pipe connector ZREV..F  
 T-piece with thermowell A-22PE-A0..

In the operating mode differential pressure control, no external setpoint is given to the Energy Valve. The setpoint is set in the device. The setting is made via web server, Belimo Assistant 2, communicative interface (BACnet, Modbus, MP-Bus) or via the Belimo Cloud. The possible setting value depends on the selected differential pressure sensor and is between 10 and 400 kPa.

Further information on the differential pressure control mode can be found in the document "Differential pressure control with the Belimo Energy Valve™".

**Product features**

**Creep flow suppression**

Given the very low flow speed in the opening point, this can no longer be measured by the sensor within the required tolerance. This range is overridden electronically.

**Opening valve**

The valve remains closed until the flow required by the control signal DDC corresponds to 1% of V'nom. The control along the flow characteristic is active after this value has been exceeded.

**Closing valve**

The control along the flow characteristic is active up to the required flow rate of 1% of V'nom. Once the level falls below this value, the flow rate is maintained at 1% of V'nom. If the level falls below the flow rate of 0.5% of V'nom required by the control signal DDC, then the valve will close.

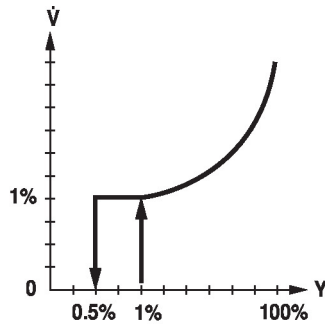

**Configurable device**

The factory settings cover the most common applications.

The configuration can be carried out through the integrated web server (RJ45 connection to the web browser) or by communicative means.

Additional information regarding the integrated web server can be found in the separate documentation.

Belimo Assistant 2 is required for configuration via Near Field Communication (NFC) and simplifies commissioning. Moreover, Belimo Assistant 2 provides a variety of diagnostic options.

**Communication**

The configuration can be carried out through the integrated web server (RJ45 connection to the web browser) or by communicative means.

Additional information regarding the integrated web server can be found in the separate documentation.

**"Peer to Peer" connection**

<https://169.254.1.1>

The Notebook must be set to "DHCP".  
Make sure that only one network connection is active.

**Standard IP address:**

<https://192.168.0.10>

Static IP address

**Password (read-only):**

User name: «guest»

Password: «guest»

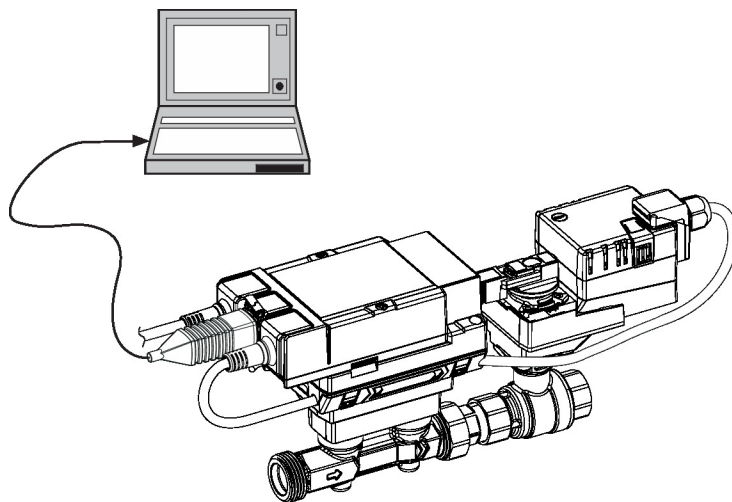

**Control signal inversion**

This can be inverted in cases of control with an analogue control signal DDC. The inversion causes the reversal of the standard behaviour, i.e. at a control signal DDC of 0%, regulation is to V'max or Q'max, and the valve is closed at a control signal DDC of 100%.

**Product features**

**Hydronic balancing** Via the integrated web server, the maximum flow rate (equivalent to 100% requirement) can be adjusted on the device itself, simply and reliably, in a few steps. If the device is integrated in the management system, then the balancing can be handled directly by the management system.

**Delta-T manager** If a heating or cooling coil is operated with a flow rate that is too high and thus with a differential temperature that is too low, this will not result in an increased power output. Low differential temperatures result in heat generators or chillers providing energy at a lower efficiency. At the same time, too much water is circulated by the pumps, which unnecessarily increases energy consumption.

With the aid of the Energy Valve, it is easy to identify operation that deviates from the design case and to locate energy that is being used inefficiently.

The integrated delta T manager offers the user the possibility to define a delta T limit value. Falling below this value is automatically avoided by the Energy Valve by limiting the flow rate.

The delta T manager can be activated in the operating modes power control, flow control and position control. The delta T manager is not available in the differential pressure control operating mode.

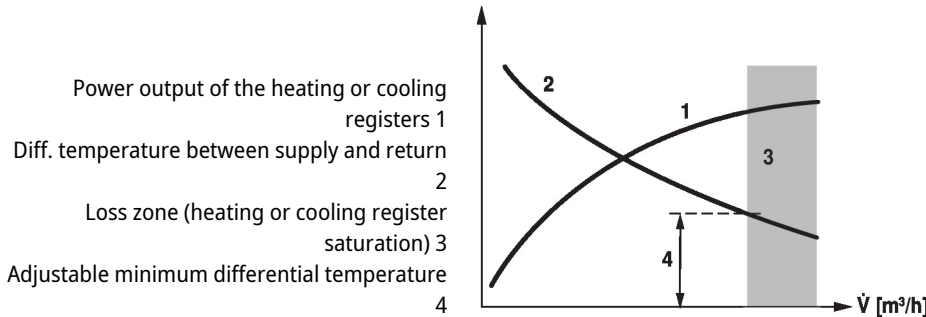

**Combination analogue - communicative (hybrid mode)** With conventional control by means of an analogue control signal DDC, the integrated web server, BACnet, Modbus or MP-Bus can be used for the communicative position feedback.

**Power and energy monitoring function** The HVAC performance device is equipped with two temperature sensors. A sensor (T2) is already installed at the thermal energy meter and the second sensor (T1) must be installed on-site on the other side of the water circuit. The two sensors are enclosed with the system already wired. The sensors are used to record the fluid temperature of the supply and return lines of the consumer (heating/cooling coil). As the water quantity is also known, thanks to the flow measurement integrated in the system, the power released from the consumer can be calculated. Furthermore, the heating/cooling energy is also determined automatically by means of the evaluation of the power over time.

The current data, e.g. temperatures, volumetric flow volumes, exchanger energy consumption etc. can be recorded and accessed at any time by means of web browsers or communication.

**Data recording** The recorded data (integrated data recording for 13 months) can be used for the optimisation of the overall system and for the determination of the performance of the consumer (heating/cooling coil).

Download csv files through web browser.

**Belimo Cloud** Additional services are available if the Energy Valve is connected to the Belimo Cloud: for instance, several devices may be managed via Internet. Also, Belimo experts may help analyse the delta-T behaviour or provide written reports about the Energy Valve performance. Under certain conditions, the product warranty according to the applicable Terms and Conditions of Sale may be prolonged. The "Terms of Use for Belimo Cloud Services" in their currently valid version apply to the use of Belimo Cloud services. Further details may be found under [www.belimo.com/ext-warranty]

**Product features**

<b>Patented glycol compensation</b>	<p>Glycol changes the viscosity of the heat transfer fluid and as a result affects the measured volumetric flow. Without glycol compensation, volumetric flow measurements can show errors of as much as 30 percent. The patented automatic glycol compensation significantly reduces the degree of measurement error.</p> <p>Selection of the fluid used:</p> <ul style="list-style-type: none"> <li>- Water</li> <li>- Propylene glycol</li> <li>- Ethylene glycol</li> <li>- Antifrogen L</li> <li>- Antifrogen N</li> <li>- DowCal 200</li> <li>- DowCal 100</li> </ul> <p>Determining the glycol concentration requires recurring temperature changes of min. 2 K within the flow sensor during operation. Installing the flow sensor in the temperature-variable part of the system is recommended to ensure these temperature changes.</p>
<b>Error readout with analogue feedback signal</b>	<p>If the sensor cannot measure the flow due to a sensor error, this is indicated by 0.3 V at the position feedback U. This is only the case if the analogue position feedback U is set to flow and the lower value of the signal range is 0.5 V or more.</p>
<b>Manual override</b>	<p>Manual override with push-button possible (the gear train is disengaged for as long as the button is pressed or remains locked).</p>
<b>High functional safety</b>	<p>The actuator is overload protected, requires no limit switches and automatically stops when the end stop is reached.</p>

**Parts included**

Description	Type
Grommet for RJ connection module with clamp	A-22PEM-A04
Thermowell Stainless steel, 50 mm, G 1/4", SW17	A-22PE-A07
Insulation shell for EPIV / Belimo Energy Valve™ DN 15...25	Z-INSH15
Insulation shell for EPIV / Belimo Energy Valve™ DN 32...50	Z-INSH32
Insulation shell not included in Asia Pacific	

**Accessories**

Replacement sensor modules	Description	Type
	Sensor module thermal energy meter DN 15	R-22PE-0UC
	Sensor module thermal energy meter DN 20	R-22PE-0UD
	Sensor module thermal energy meter DN 25	R-22PE-0UE
	Sensor module thermal energy meter DN 32	R-22PE-0UF
	Sensor module thermal energy meter DN 40	R-22PE-0UG
	Sensor module thermal energy meter DN 50	R-22PE-0UH
Tools	Description	Type
	Service tool for wired and wireless setup, on-site operation and troubleshooting.	Belimo Assistant 2
	Belimo Assistant Link Bluetooth and USB to NFC and MP-Bus converter for configurable and communicative devices	LINK.10
Gateways	Description	Type
	Converter M-Bus	G-22PEM-A01
Mechanical accessories	Description	Type
	T-piece with thermowell DN 15	A-22PE-A01
	T-piece with thermowell DN 20	A-22PE-A02
	T-piece with thermowell DN 25	A-22PE-A03
	T-piece with thermowell DN 32	A-22PE-A04
	T-piece with thermowell DN 40	A-22PE-A05
	T-piece with thermowell DN 50	A-22PE-A06

## Accessories

Description	Type
Thermowell Stainless steel, 80 mm, G 1/2", SW27	A-22PE-A08
Valve neck extension for ball valve DN 15...50	ZR-EXT-01
Pipe connector for ball valve with internal thread DN 15 Rp 1/2"	ZR2315
Pipe connector for ball valve with internal thread DN 20 Rp 3/4"	ZR2320
Pipe connector for ball valve with internal thread DN 25 Rp 1"	ZR2325
Pipe connector for ball valve with internal thread DN 32 Rp 1 1/4"	ZR2332
Pipe connector for ball valve with internal thread DN 40 Rp 1 1/2"	ZR2340
Pipe connector for ball valve with internal thread DN 50 Rp 2"	ZR2350
Pipe connector for EPIV / Energy valve with external thread DN 15 Rp 1/2", G 3/4"	ZREV15F
Pipe connector for EPIV / Energy valve with external thread DN 20 Rp 3/4", G 1"	ZREV20F
Pipe connector for EPIV / Energy valve with external thread DN 25 Rp 1", G 1 1/4"	ZREV25F
Pipe connector for EPIV / Energy valve with external thread DN 32 Rp 1 1/4", G 1 1/2"	ZREV32F
Pipe connector for EPIV / Energy valve with external thread DN 40 Rp 1 1/2", G 2"	ZREV40F
Pipe connector for EPIV / Energy valve with external thread DN 50 Rp 2", G 2 1/2"	ZREV50F

## Electrical installation



Supply from isolating transformer.

Parallel connection of other actuators possible. Observe the performance data.

The wiring of the line for BACnet MS/TP / Modbus RTU is to be carried out in accordance with applicable RS-485 regulations.

Modbus / BACnet: Supply and communication are not galvanically isolated. COM and ground of the devices must be connected to each other.

Sensor connection: An additional sensor can optionally be connected to the thermal energy meter. This can be a passive resistance sensor Pt1000, Ni1000, NTC10k (10k2), an active sensor with output DC 0...10 V or a switching contact. Thus the analogue signal of the sensor can be easily digitised with the thermal energy meter and transferred to the corresponding bus system.

Analogue output: An analogue output (wire 5) is available on the thermal energy meter. It can be selected as DC 0...10 V, DC 0.5...10 V or DC 2...10 V. For example, the flow rate or the temperature of the temperature sensor T1/T2 can be output as an analogue value.

**Wire colours:**

- 1 = black
- 2 = red
- 3 = white
- 5 = orange
- 6 = pink
- 7 = grey

**Functions:**

- C1 = D- (wire 6)
- C2 = D+ (wire 7)

AC/DC 24 V, output signal

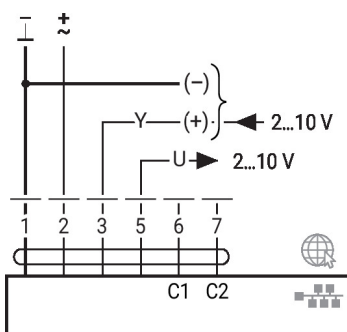

**Electrical installation**

BACnet MS/TP / Modbus RTU

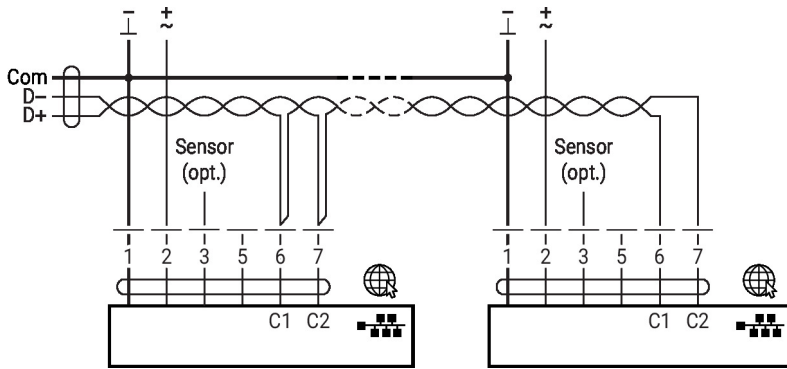

BACnet/IP / Modbus TCP

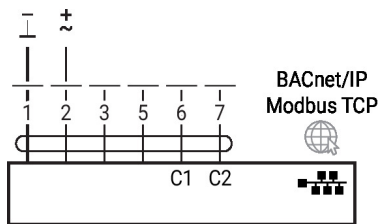

PoE with BACnet/IP / Modbus TCP

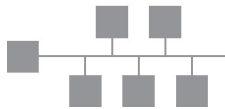
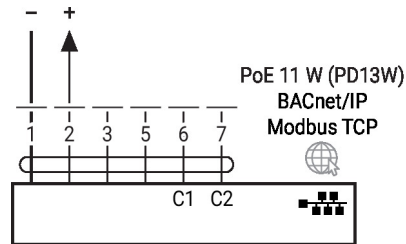

Optional connection via RJ45  
(direct connection to notebook /  
connection via Intranet or  
Internet) for access to the  
integrated web server

**Converter for sensors**

Connection with passive sensor

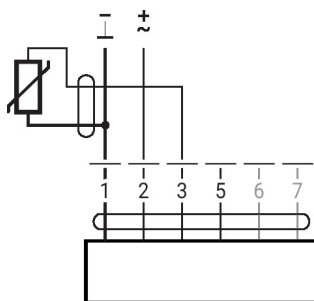

Connection with switching contact

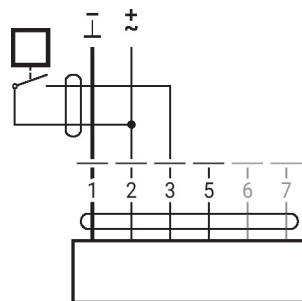

Connection with active sensor

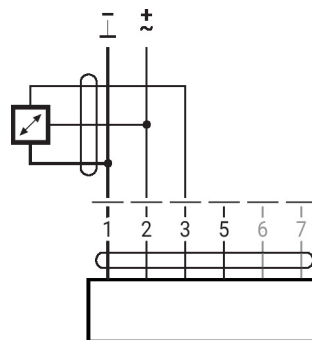

Further electrical installations

Functions with specific parameters (configuration necessary)

Override control and limiting with AC 24 V with relay contacts (with conventional control or hybrid mode, not for differential pressure control)

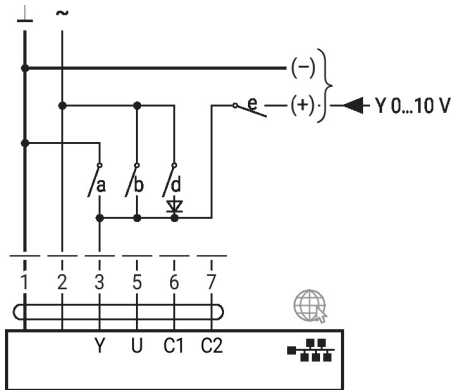

1	2	a	b	d	e		Inv.
						Close <sup>1)</sup>	Open <sup>1)</sup>
						V' <sub>min</sub> <sup>2)</sup>	V' <sub>max</sub> <sup>2)</sup>
						Q' <sub>min</sub> <sup>3)</sup>	Q' <sub>max</sub> <sup>3)</sup>
						V' <sub>max</sub>	V' <sub>max</sub>
						Open	Open
						Y	Y

- 1) Position control
- 2) Flow control
- 3) Power control
- Inv. = control signal inverted

Override control and limiting with DC 24 V with relay contacts (with conventional control or hybrid mode, not for differential pressure control)

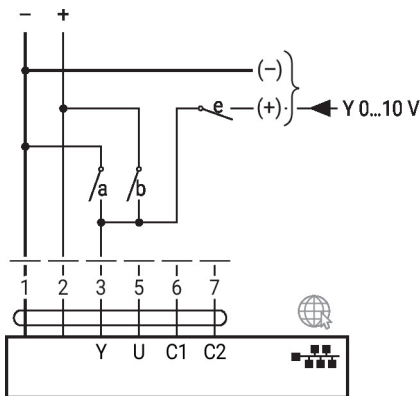

1	2	a	b	e		Inv.
					Close <sup>1)</sup>	Open <sup>1)</sup>
					V' <sub>min</sub> <sup>2)</sup>	V' <sub>max</sub> <sup>2)</sup>
					Q' <sub>min</sub> <sup>3)</sup>	Q' <sub>max</sub> <sup>3)</sup>
					Y	Y
					Open <sup>1)</sup>	Open <sup>1)</sup>
					V' <sub>max</sub> <sup>2)</sup>	V' <sub>max</sub> <sup>2)</sup>
					Q' <sub>max</sub> <sup>3)</sup>	Q' <sub>max</sub> <sup>3)</sup>

- 1) Position control
- 2) Flow control
- 3) Power control
- Inv. = control signal inverted

BACnet MS/TP / Modbus RTU with analogue setpoint (hybrid mode)

BACnet/IP / Modbus TCP with analogue setpoint (hybrid mode)

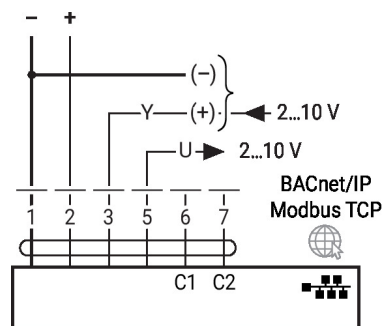
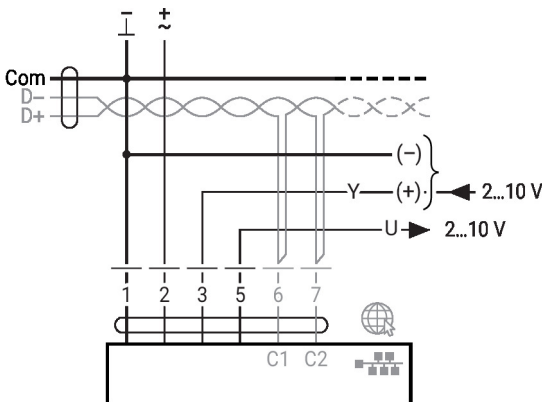

**Further electrical installations**

**Functions with specific parameters (configuration necessary)**

MP-Bus, supply via 3-wire connection

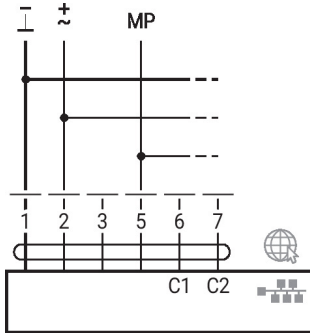

MP-Bus via 2-wire connection, local power supply

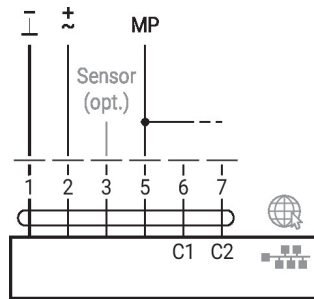

MP-Bus with analogue setpoint (hybrid mode)

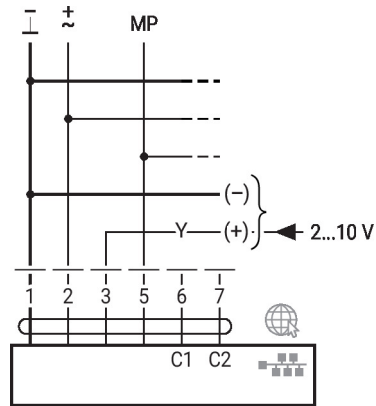

M-Bus with converter

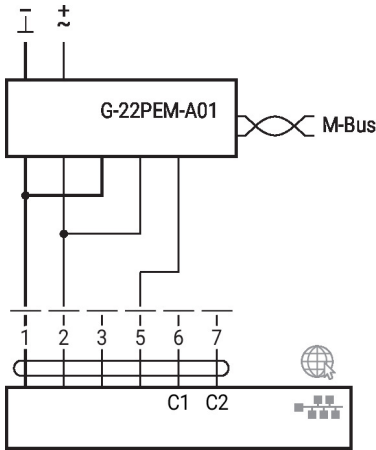

M-Bus parallel Modbus TCP or BACnet/IP with PoE

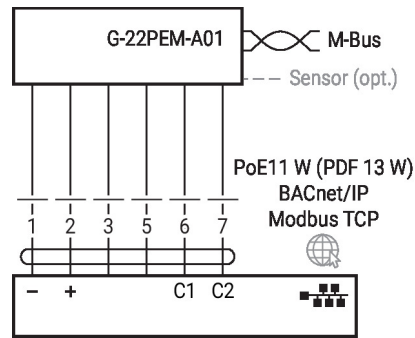

M-Bus via Converter M-Bus

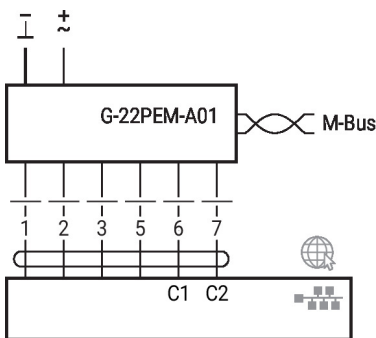

M-Bus parallel Modbus RTU or BACnet MS/TP

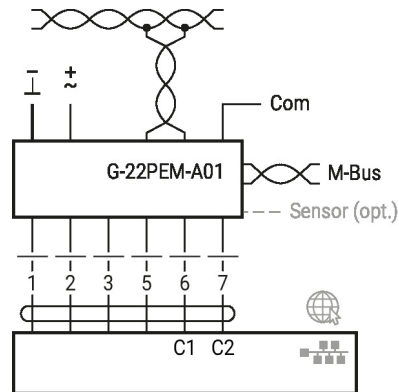

**Further electrical installations**

**Functions with specific parameters (configuration necessary)**

M-Bus parallel Modbus TCP or BACnet/IP

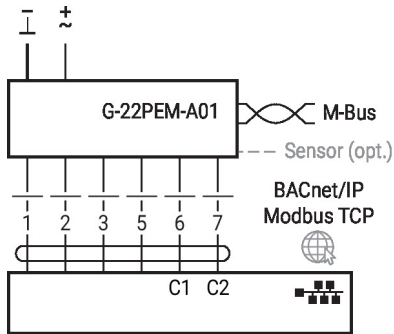

**Operating mode differential pressure control**

Connection of differential pressure sensor 22WDP-11.. (sensor not included)

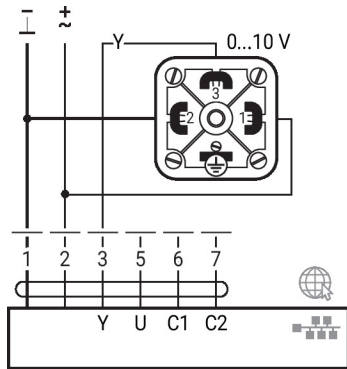

Connection of differential pressure sensor 22PDP-18.. (sensor not included)

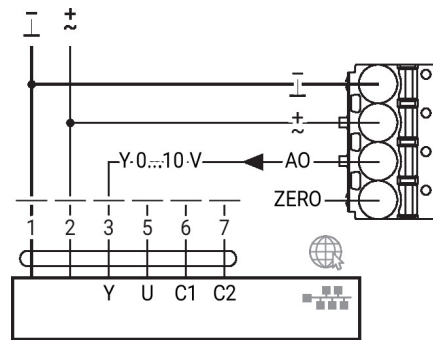

Operating controls and indicators

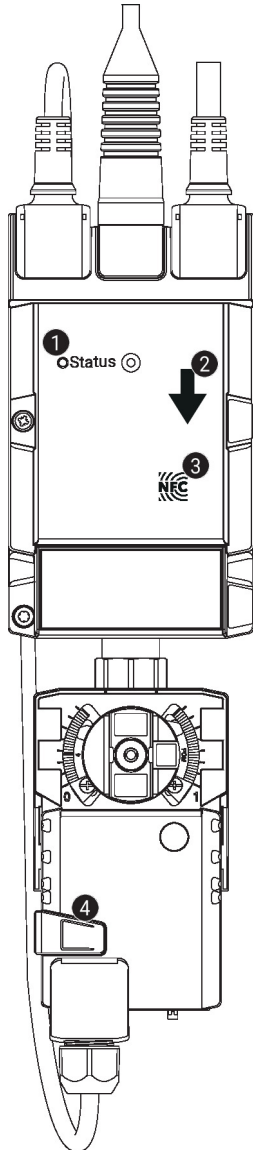

**1 LED display green**

On:	Device starting up
Flashing:	In operation (Power ok)
Off:	No power

**2 Flow direction**

**3 NFC interface**

**4 Manual override button**

Press button:	Gear train disengages, motor stops, manual override possible
Release button:	Gear train engages, standard mode. Device performs synchronisation

Installation notes

**Permissible installation orientation**

The ball valve can be installed upright to horizontal. The ball valve may not be installed in a hanging position, i.e. with the spindle pointing downwards.

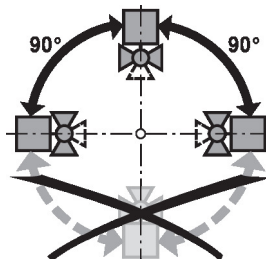

**Installation location in return**

Installation in the return is recommended.

**Water quality requirements**

The water quality requirements specified in VDI 2035 must be adhered to. Belimo valves are regulating devices. For the valves to function correctly in the long term, they must be kept free from particle debris (e.g. welding beads during installation work). The installation of a suitable strainer is recommended.

## Installation notes

- Servicing** Ball valves, rotary actuators and sensors are maintenance-free.
- Before any service work on the control element is carried out, it is essential to isolate the rotary actuator from the power supply (by unplugging the electrical cable if necessary). Any pumps in the part of the piping system concerned must also be switched off and the appropriate slide valves closed (allow all components to cool down first if necessary and always reduce the system pressure to ambient pressure level).
- The system must not be returned to service until the ball valve and the rotary actuator have been correctly reassembled in accordance with the instructions and the pipeline has been refilled by professionally trained personnel.
- Flow direction** The direction of flow, specified by an arrow on the housing, is to be complied with, since otherwise the flow rate will be measured incorrectly.
- Cleaning of pipes** Before installing the thermal energy meter, the circuit must be thoroughly rinsed to remove impurities.
- Prevention of stresses** The thermal energy meter must not be subjected to excessive stress caused by pipes or fittings.
- Inlet section** A flow calming section or inlet section in the direction of the flow must be maintained in front of the flow sensor to achieve the specified measuring accuracy.
- According to EN 1434-4:2022 (out-of-plane double 90° bends), an inlet section of 0x DN is applicable. In all other cases, EN 1434-6:2022, Annex A.4, recommends an inlet section of  $\geq 5x$  DN. See also the Belimo application information on the inlet section according to EN 1434.
- Recommended installation locations
  - Prohibited installation location due to the danger of air accumulation
  - Installation immediately after valves is prohibited. Exception: If it is a shut-off valve without constriction and it is 100% open
  - Installation on the suction side of a pump is not recommended

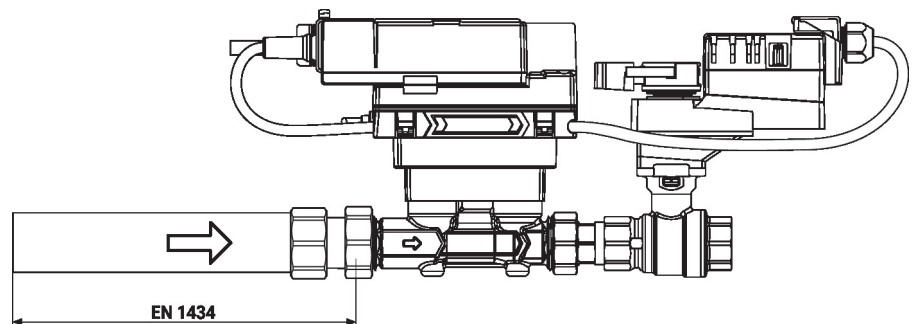

## Installation notes

**Mounting of immersion sleeve and temperature sensor**

The valve is equipped with two fully-wired temperature sensors.

- T2: This sensor is installed in the thermal energy meter.
- T1: This sensor has to be installed on site ahead of the consumer (valve in the return line; recommended) or after the consumer (valve in the supply line).

**Note**

The cables between valve unit and temperature sensors may not be shortened or extended.

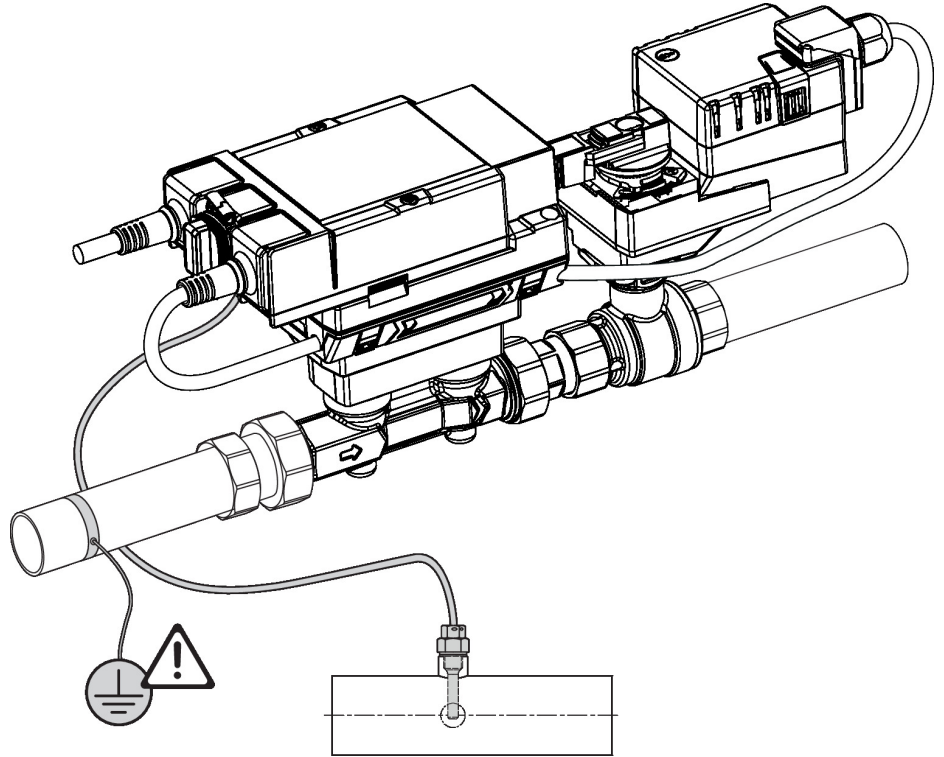
**Split installation**

The valve-actuator combination may be mounted separately from the flow sensor. The direction of flow of both components must be observed.

## General notes

**Valve selection**

The valve is determined using the maximum required flow rate  $V'_{max}$ .

A calculation of the  $K_{vs}$  value is not required.

$V'_{max} = 30...100\%$  of  $V'_{nom}$

If no hydronic data is available, the same valve DN can be selected as the heat exchanger nominal diameter.

## General notes

**Minimum differential pressure (pressure drop)**

The minimum required differential pressure (pressure drop through the valve) for achieving the desired flow  $V'_{max}$  can be calculated with the aid of the theoretical  $K_{vs}$  value (see type overview) and the below-mentioned formula. The calculated value is dependent on the required maximum flow  $V'_{max}$ . Higher differential pressures are compensated for automatically by the valve.

Formula

$$\Delta p_{min} = 100 \times \left( \frac{V'_{max}}{K_{vs \text{ theor.}}} \right)^2$$

$\Delta p_{min}$ : kPa  
 $V'_{max}$ : m<sup>3</sup>/h  
 $K_{vs \text{ theor.}}$ : m<sup>3</sup>/h

Example (DN 25 with the desired maximum flow rate = 50%  $V'_{nom}$ )

EV025R2+BAC

$K_{vs \text{ theor.}}$  = 8.8 m<sup>3</sup>/h

$V'_{nom}$  = 58.3 l/min

50% x 58.3 l/min = 29.2 l/min = 1.75 m<sup>3</sup>/h

$$\Delta p_{min} = 100 \times \left( \frac{V'_{max}}{K_{vs \text{ theor.}}} \right)^2 = 100 \times \left( \frac{1.75 \text{ m}^3/\text{h}}{8.8 \text{ m}^3/\text{h}} \right)^2 = 4 \text{ kPa}$$

**Behaviour in case of sensor failure**

In case of a flow sensor error, the Energy Valve will switch from either power or flow control to position control (Delta-T manager will be deactivated).

Once the error disappears, the Energy Valve will switch back to the normal control setting (Delta-T manager activated)

## Service

**Wireless connection**

Belimo devices marked with the NFC logo can be operated with Belimo Assistant 2.

Requirement:

- NFC- or Bluetooth-capable smartphone
- Belimo Assistant 2 (Google Play and Apple App Store)

Align NFC-capable smartphone on the device so that both NFC antennas are superposed.

Connect Bluetooth-enabled smartphone via the Bluetooth-to-NFC converter ZIP-BT-NFC to the device. Technical data and operating instructions are shown in the ZIP-BT-NFC data sheet.

Readable values: volumetric flow, accumulated flow, fluid temperature, glycol content in %, alarm/error messages

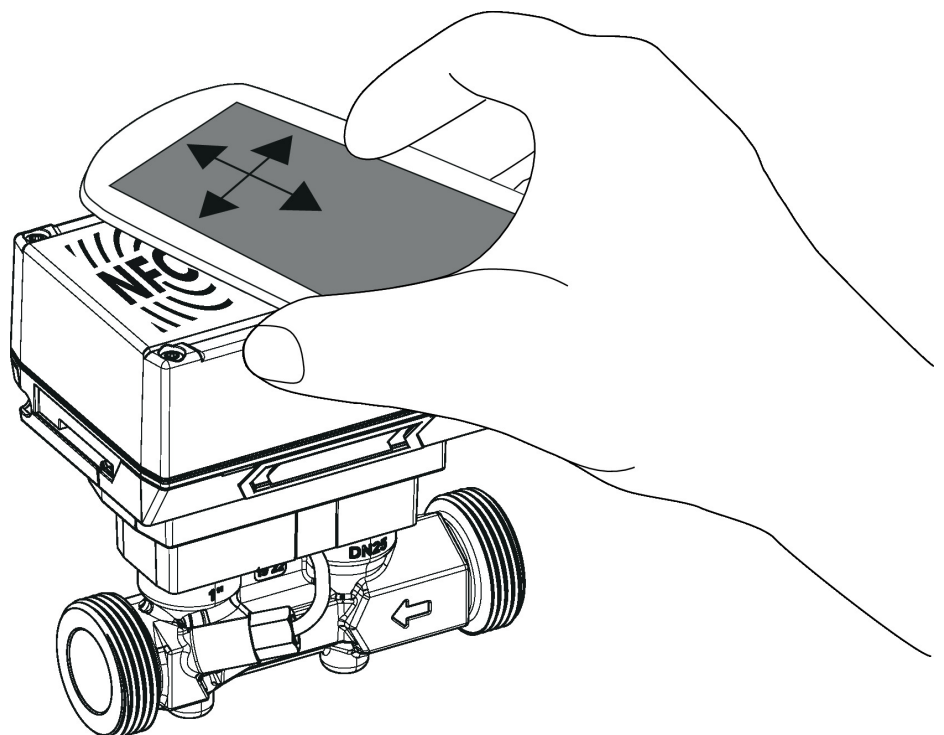

## Dimensions

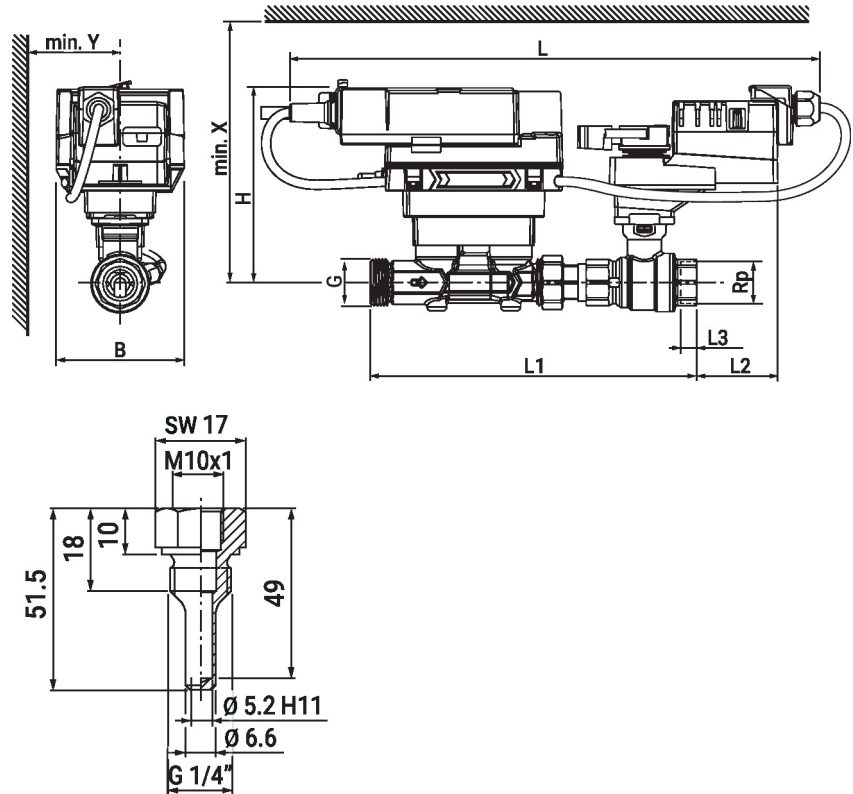

Type	DN	Rp	G	L	L1	L2	L3	B	H	X	Y	kg
		["]	["]	[mm]	[mm]	[mm]	[mm]	[mm]	[mm]	[mm]	[mm]	
EV015R2+BAC	15	1/2	3/4	362	195	62	13	90	136	206	80	2.2
EV020R2+BAC	20	3/4	1	374	230	57	14	90	137	207	80	2.4
EV025R2+BAC	25	1	1 1/4	381	246	51	16	90	140	210	80	2.8
EV032R2+BAC	32	1 1/4	1 1/2	398	267	50	19	90	143	213	80	3.5
EV040R2+BAC	40	1 1/2	2	404	280	45	19	90	147	217	80	4.2
EV050R2+BAC	50	2	2 1/2	421	294	49	22	90	152	222	80	5.1

## Further documentation

- Data sheet thermal energy meter
- Overview MP Cooperation Partners
- Tool connections
- General notes for project planning
- Instruction Webserver
- Description Data-Pool Values
- BACnet Interface description
- Modbus Interface description
- Introduction to MP-Bus Technology
- Installation instructions for actuators and/or ball valves
- Differential pressure control with the Belimo Energy Valve™
- Application information inlet section according to EN 1434
- Quick Guide – Belimo Assistant 2