

HƯỚNG DẪN CÀI ĐẶT BTU BELIMO

I. Mục Đích

Để kích hoạt đồng hồ đo năng lượng nhiệt Belimo, người dùng cần tạo tài khoản Belimo Cloud, hoàn thành khóa học trực tuyến, tải ứng dụng Belimo Assistant, cấu hình vị trí lắp đặt, và thực hiện kích hoạt một lần duy nhất qua ứng dụng. Quá trình này yêu cầu cẩn thận vì kích hoạt sai sẽ dẫn đến đo lường không chính xác và không thể đảo ngược.

Website tham khảo: https://www.belimo.com/ch/en_GB/products/sensors/product-documentation/tem-activation

II. Các bước thao tác:

1. Tạo tài khoản Belimo Cloud:

- Đăng ký tài khoản trên nền tảng Belimo Cloud.
- Hoàn thành mô-đun học trực tuyến (e-learning module) do Belimo cung cấp để được cấp quyền thực hiện kích hoạt đồng hồ đo năng lượng nhiệt.

2. Tải và cài đặt ứng dụng Belimo Assistant:

- Tải ứng dụng Belimo Assistant từ kho ứng dụng tương ứng (Google Play cho Android, App Store cho iOS, hoặc Microsoft Store cho Windows).
- Cài đặt ứng dụng trên điện thoại thông minh, máy tính bảng hoặc PC.



3. Cấu hình vị trí lắp đặt:

- Mở ứng dụng Belimo Assistant và sử dụng giao diện NFC (giao tiếp trường gần) hoặc web server tích hợp trong đồng hồ để kết nối.
- Chọn vị trí lắp đặt của đồng hồ trong hệ thống (trên đường cấp – supply line hoặc đường hồi – return line) theo thiết kế hệ thống.

4. Kích hoạt đồng hồ:

- Trong ứng dụng Belimo Assistant, thực hiện quy trình kích hoạt một lần duy nhất (one-time activation).
- Xác nhận các thông tin đã cấu hình và hoàn tất kích hoạt.
- Lưu ý: Quá trình này không thể đảo ngược. Nếu kích hoạt sai (ví dụ: chọn nhầm vị trí lắp đặt), đồng hồ sẽ đo lường không chính xác và cần được thay thế.

Lưu ý quan trọng:

- Tham khảo Hướng dẫn vận hành (Operations Manual) của thiết bị để đảm bảo thực hiện đúng quy trình.
- Đảm bảo thiết bị được cấp nguồn và kết nối ổn định trong quá trình kích hoạt.

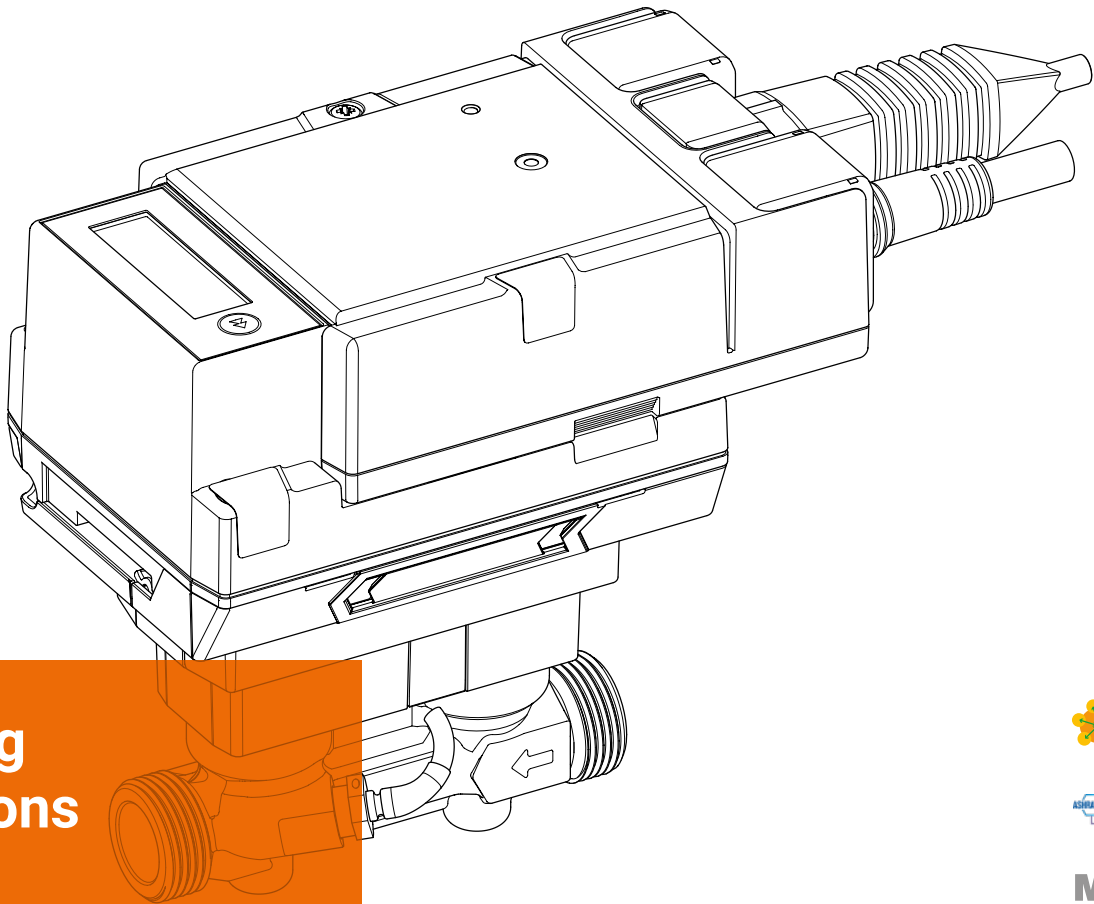

Operating instructions



Thermal Energy Meters 22PEM-1U.. MID 2014/32/EU EN 1434

Edition 02.2025/D

Table of contents

Notes

General information	3
Legal notice	5
Installation notes	6

Supply voltage

10

Operating controls and indicators

11

Wiring diagrams

Notes	
Connection assignment	12
Analogue output connection	
Connections to BACnet, Modbus, MP-Bus	13
Connection of external sensors/switches	14
Connection to M-Bus via M-Bus converter	

Activation of the thermal energy meter

Display symbols	15
Notes on activation	16
Procedure for activation	17

Display loops

User loop	22
Diagnostic loop	24

Error codes

26

Sealing and security sealing

Factory-applied seals	28
Security sealing on the system	29
Properly affixing security seals	30

Exchanging the sensor module

31

Sensor module as a spare part

34

Accessories

Optional accessories	35
----------------------	----

Notes

General information

Use and function

The thermal energy meter records the thermal energy in closed heating, cooling systems or heating/cooling systems.

Approval

The thermal energy meter meets the requirements of EN 1434 and has type approval according to the European Measuring Instruments Directive 2014/32/EU (MI-004). The thermal energy meter is approved as a heat meter. In certain European countries, based on local regulations, the thermal energy meter is not approved for use as a cooling meter. In these countries, it is not legally compliant to use the thermal energy meter as a cooling meter in legal transactions. But it is possible to use the thermal energy meter as a cooling meter for "internal use" at any time.

Scope of delivery

- Thermal energy meter
- Two security seals consecutively numbered (unique number) with attached wire approx. 40 cm
- Insulation shell
- Silicone grommet
- Installation instructions

Water quality requirements

The measuring stability of the meters is only given if the water quality meets the conditions of AGFW recommendation FW-510 and VDI 2035.

Energy meter installation

Before commissioning and installing the thermal energy meter, the operating instructions should be carefully studied to prevent errors during installation and commissioning.

The operating instructions are valid for the following thermal energy meters

Product type from Belimo	DN	DN (")	G (")	Product type from Belimo (m³/h)
22PEM-1UC	15	1/2	3/4	1.5
22PEM-1UD	20	3/4	1	2.5
22PEM-1UE	25	1	1 1/4	3.5
22PEM-1UF	32	1 1/4	1 1/2	6
22PEM-1UG	40	1 1/2	2	10
22PEM-1UH	50	2	2 1/2	15

Structure of the thermal energy meter

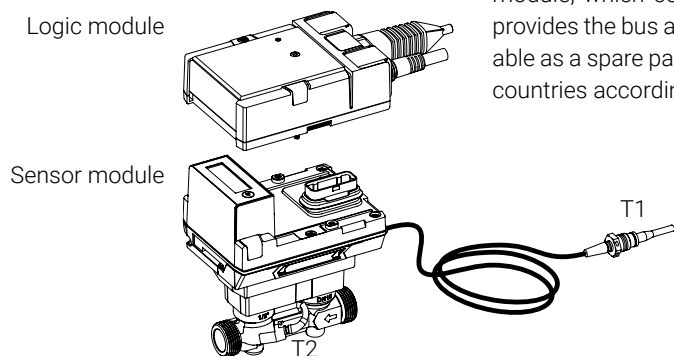

The thermal energy meter consists of a sensor module with connected temperature sensors, which houses the calculator unit and measuring system, and the logic module, which connects the thermal energy meter to the power supply and provides the bus and NFC communication interface. The sensor module is available as a spare part and must be replaced periodically for recalibration in certain countries according to national regulations.

Belimo Assistant 2



NFC connection



For successful commissioning/activation of the thermal energy meter, it is necessary to set system-specific parameters using the Belimo Assistant 2. Communication from the smartphone to the thermal energy meter takes place via NFC (Near Field Communication). The settings made in the process are finally shown on the display of the thermal energy meter for verification (see chapter "Activation of the thermal energy meter").

The NFC logo on the thermal energy meter indicates that the device can be operated with the Belimo Assistant 2.

Requirement:

- NFC or Bluetooth-enabled smartphone
- Belimo Assistant 2 (Google Play and Apple App Store)

NFC: position the NFC-enabled smartphone on the thermal energy meter so that both NFC antennas of the smartphone and thermal energy meter are on top of each other.

Bluetooth: connect the Bluetooth-enabled smartphone to the thermal energy meter via Bluetooth-NFC converter ZIP-BT-NFC.

Technical data and operating instructions can be found on the ZIP-BT-NFC data sheet.

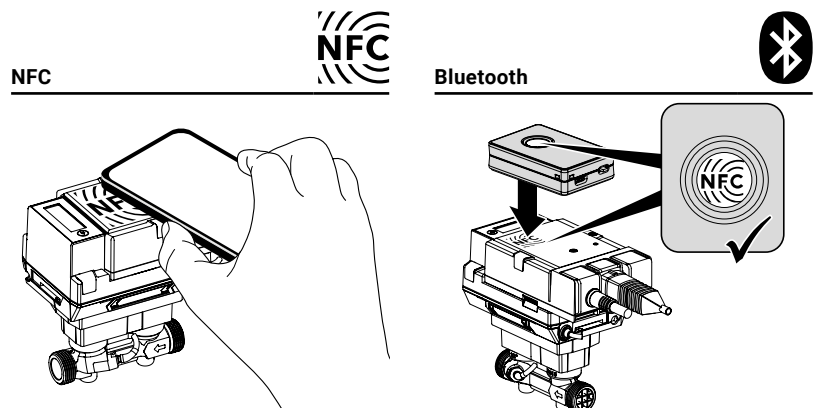

Calibration certificate

A calibration certificate is available in the Belimo Cloud for each thermal energy meter. If required, this can be downloaded as a PDF with the Belimo Assistant 2 or via the Belimo Cloud frontend.

Selecting the physical address

In order for the thermal energy meter to operate successfully with bus communication, the device must be assigned a physical address. The address is programmed using the Belimo Assistant 2 or the web server.

Legal notice

Authorisation

The thermal energy meter has left the factory in perfect condition. All installation work may only be carried out by a trained and authorised specialist.

MID conformity and guarantee

The factory seals of the thermal energy meter must not be changed, damaged or removed - otherwise the guarantee and MID conformity of the device are void.

Application for cooling measurement

Optionally, the thermal energy meter can display the accumulated cooling quantity in addition to the accumulated heat quantity. In doing so, the national regulations regarding the measurement of cooling quantities must be observed. In certain European countries, based on local regulations, the thermal energy meter is not approved for use as a cooling meter and cannot be calibrated. In these countries, it is not legally compliant to use the thermal energy meter as a cooling meter in legal transactions. But it is possible to use the thermal energy meter as a cooling meter for "internal use" at any time.

Use of Belimo Cloud Services

Use of Belimo Cloud Services is governed by the "Terms of Use for Belimo Cloud Services" in their currently valid version. Cloud usage can be disabled in the Startup Assistant of the web server or in the general settings of the Belimo Assistant 2 if required.

Data protection

Please consider the principles of data security and data privacy when using the device. This applies in particular if the device is used in residential buildings. For this purpose, the initial password for remote access (webserver) needs to be changed when configuring the device. Moreover, physical access to the device should be restricted so that only authorised persons may access the device. Alternatively, the device offers the option to permanently disable access through the NFC interface.

Installation notes

Installation orientation

- a) Recommended installation orientation
- b) Prohibited installation orientation due to the risk of air accumulation
- c) Acceptable installation orientation in closed systems
- d) Installation directly downstream from valves is prohibited.
Exception: If it is an open/close valve without constriction and is 100% open.
- e) Installation on the suction side of a pump is not recommended.
- f) The thermal energy meter must not be installed upside down.
- g) Upright to horizontal installation is permitted, but suspended installation is prohibited.

Inlet section

- h) A calming section or inlet section must be maintained in front of the flow sensor to achieve the specified measuring accuracy.
According to EN 1434-4:2022 (out-of-plane double bends 90°), an inlet section of 0x DN is applicable. In all other cases, EN 1434-6:2022, annex A.4 recommends an inlet section of $\geq 5x$ DN. Also see Belimo application information Inlet section according to EN 1434.

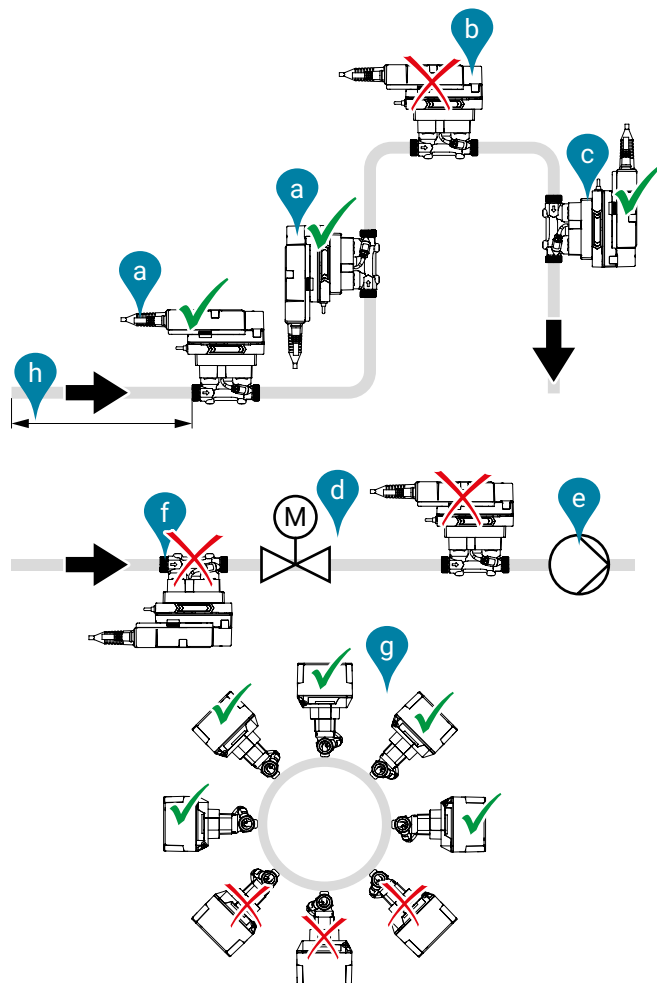

Direction of flow

The direction of flow indicated by an arrow on the logic module and flow sensor body must be complied with, otherwise the flow will be measured incorrectly or not at all.

Preventing cavitation

To prevent cavitation, the system pressure at the output of the thermal energy meter must be at least 1 bar at q_s (maximum flow) and temperatures up to 90°C. At a temperature of 120°C the system pressure at the output of the thermal energy meter must be at least 2.5 bar.

Installation of temperature sensor T1

For new installations, direct installation of temperature sensor T1 is preferred. National regulations must be observed when using (stock) thermowells.

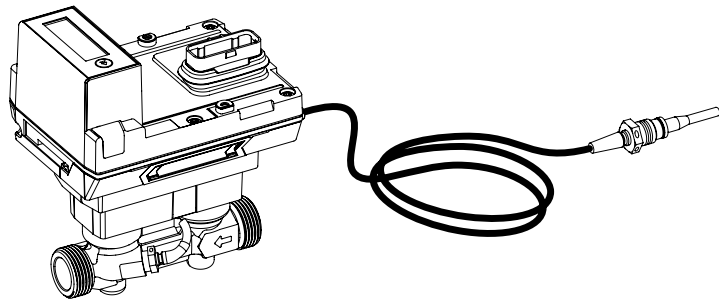

The connecting cable of temperature sensor T1 should not be laid along hot pipes or wound around them, as the wire resistance and its temperature dependency affect the measurement result of temperature sensors in 2-conductor technology.

Installation in the return (default)

Assignment and parametrisation

The Belimo Assistant 2 must be used to inform the thermal energy meter that it is located in the return (see chapter "Activation of the thermal energy meter").



Picture 1 shows the principle. The thermal energy meter is located in the return of the consumer. Temperature sensor T2 installed directly in the sensor module records the return temperature. The external temperature sensor T1 can be installed via the ball valve with measuring port M10x1, which is located in the supply. During installation of the sensor ensure that the gasket surrounding the sensor is clean and has a proper fit. The brass screw connection of the sensor is tightened slightly (6...10 Nm) with an open-end wrench.

After checking the installation, temperature sensor T1 is fitted with a security seal (protection against manipulation). The security seal is included in the scope of delivery.

When installing the thermal energy meter, the direction of flow must be considered. The direction of flow is indicated by the arrows on the flow sensor body (on both sides) and on the logic module. The thermal energy meter is installed between two open/close valves. After installation, one of the open/close valves along with the flow sensor body is fitted with a security seal (protection against manipulation). The security seal is included in the scope of delivery. Temperature sensors T1 and T2 are permanently connected to the thermal energy meter. The cable length must not be changed. If the sensor module is replaced, both temperature sensors T1 and T2 are also replaced.

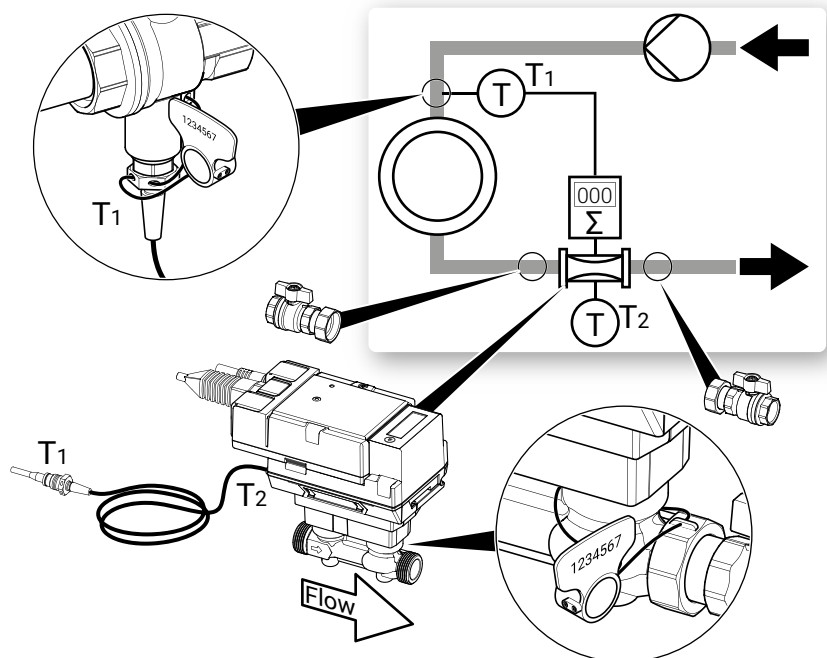

Picture 1

Installation in the supply (alternative)

Assignment and parametrisation

The Belimo Assistant 2 must be used to inform the thermal energy meter that it is located in the supply (see chapter "Activation the thermal energy meter").



Picture 2 shows the principle (alternative). The thermal energy meter is located in the supply. Temperature sensor T2 installed directly in the sensor module records the supply temperature. The external temperature sensor T1 can be installed via the ball valve with measuring port M10x1, which is located in the return. During installation of the sensor ensure that the gasket surrounding the sensor is clean and has a proper fit. The brass screw connection of the sensor is tightened slightly (6...10 Nm) with an open-end wrench.

After checking the installation, temperature sensor T1 is fitted with a security seal (protection against manipulation). The security seal is included in the scope of delivery.

When installing the thermal energy meter, the direction of flow must be considered. The direction of flow is indicated by the arrows on the flow sensor body (on both sides) and on the logic module. The thermal energy meter is installed between two open/close valves. After installation, one of the open/close valves along with the flow sensor body is fitted with a security seal (protection against manipulation). The security seal is included in the scope of delivery. Temperature sensors T1 and T2 are permanently connected to the thermal energy meter. The cable length must not be changed. If the sensor module is replaced, both temperature sensors T1 and T2 are also replaced.

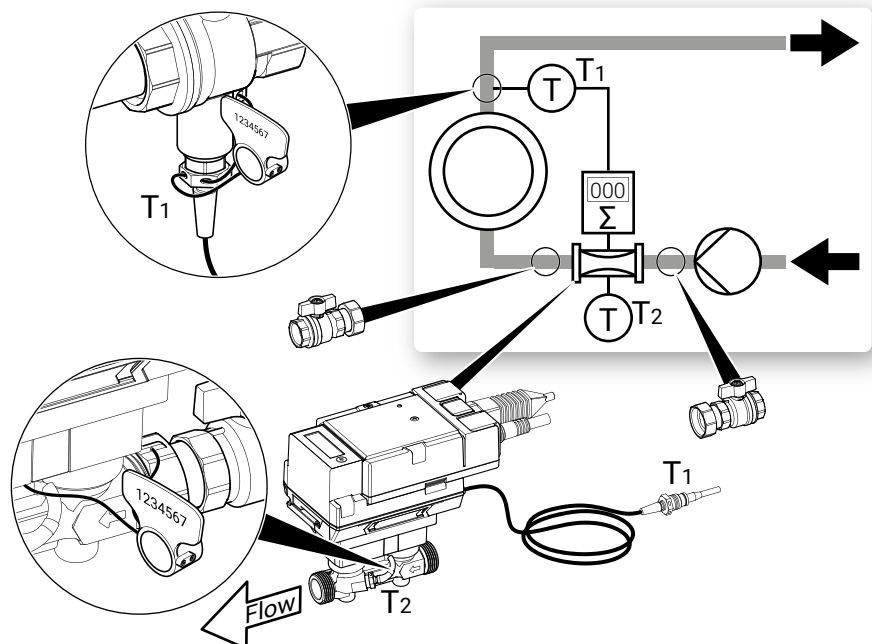

Picture 2

Supply voltage

Supply with AC/DC 24 V

The supply voltage of the thermal energy meter is 24 V AC or DC.

Supply via PoE

Alternatively, the thermal energy meter can be supplied with Power over Ethernet (PoE) via the Ethernet socket. The meter requires at least 11 W from the PoE switch for operation. The PoE switch must support the IEEE 802.3af, class 3 standard or higher.

It is also possible for the PoE supplied thermal energy meter to supply an external device such as an actuator or an active sensor, as described in the "Wiring diagrams" chapter. Wires 1 and 2 of the meter are used as 24 VDC voltage output and must not be supplied with external voltage at the same time. The maximum output power is 8 W. The PoE supply of the external device can be activated via the Belimo Assistant 2 under the item "power supply" on the device.

Caution: PoE may only be enabled if an external device is connected to wires 1 and 2 or wires 1 and 2 are insulated!



Backup battery

The thermal energy meter is equipped with a non-rechargeable backup battery to bridge possible power failures for a total 14 months.

The battery is activated when the thermal energy meter is activated and ensures that the thermal energy continues to be reliably recorded in the event of temporary power failures. While the thermal energy meter is running on the battery, the values can only be read out via the display.

Active use of the display (pressing the button next to it) reduces the battery capacity and thus the possible bridging time for power failures. It is therefore recommended to restore the power supply as soon as possible.

In the case of battery operation, the sensor data sampling rates are reduced. The thermal energy meter must not be installed in such a way that intentional voltage interruptions are possible.

Operating controls and indicators

Status LED display

LED	Status
Lights up continuously	Device starts
Flashing	Device in operation
Off	No voltage

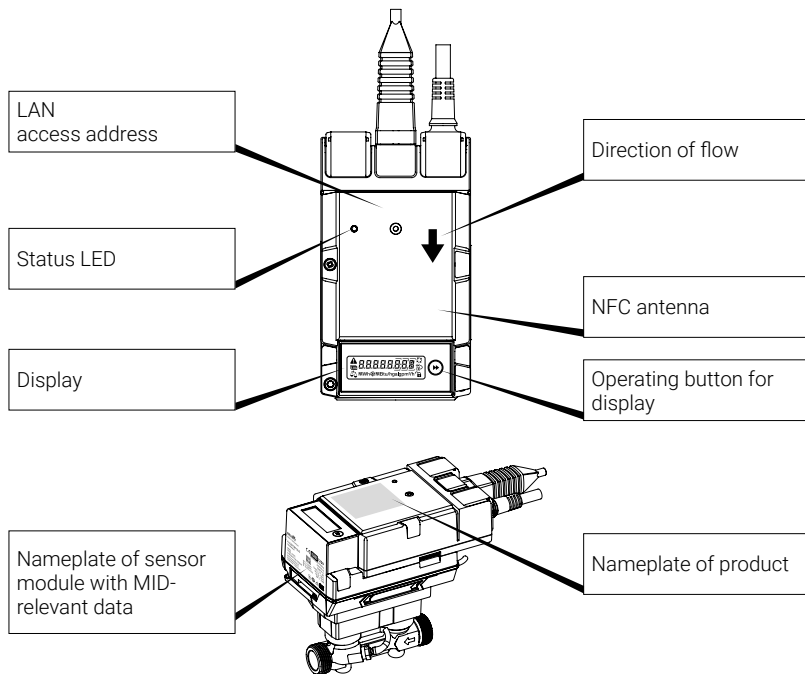

Nameplate of sensor module with MID-relevant data

(Example DN 15)

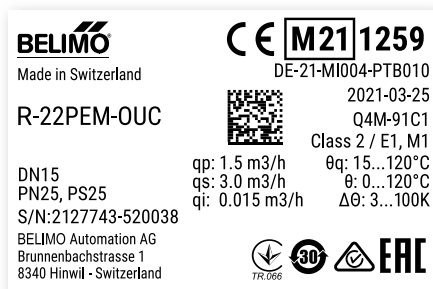

Wiring diagrams

Notes



- Supply with isolating transformer
- The wiring of the line for BACnet MS/TP and Modbus RTU must be carried out according to the relevant RS-485 guidelines.
- Modbus/BACnet: power supply and communication are not galvanically separated. Connect earth signal for devices with one another.
- Sensor interface: a sensor can optionally be connected to the thermal energy meter. This can be a passive resistance sensor (Pt1000, Ni1000 or NTC), an active sensor (e.g. with a DC 0...10 V output) or a switching contact. As a result, the analogue signal of the sensor can be easily digitised with the thermal energy meter and transferred to the corresponding bus system.
- Analogue output: an analogue output is available at the thermal energy meter. This can be selected as DC 0...10 V, DC 0.5...10 V or DC 2...10 V and freely selectable within the specified limits. For example, the flow or the temperature of temperature sensor T1/T2 can be output as an analogue value.
- IP protection: IP protection is only guaranteed if either the Ethernet connector socket is protected with the cover cap or a connected Ethernet cable is protected with the enclosed silicone grommet. The clamp that fastens the silicone grommet must be tightened to a torque of 0.3 Nm.
- Equipotential bonding: equipotential bonding must be installed on the flow sensor body, if this is not already done via the pipeline.

Connection assignment

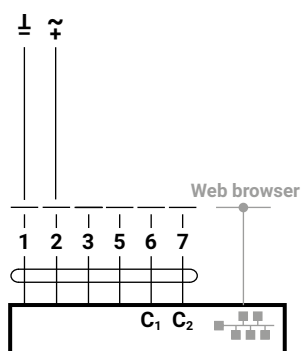

Wire colours:

- 1 = black, GND
- 2 = red, AC/DC 24 V
- 3 = white, sensor
- 5 = orange, MP, DC 0...10 V
- 6 = pink, C1 = D- = A
- 7 = grey, C2 = D+ = B

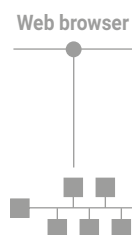

Connection RJ45

- PoE
- BACnet/IP
- Modbus TCP
- TCP/IP
- Belimo Cloud
- Web server

Note: the connection to the Belimo Cloud is permanently available. Activation takes place via web server or Belimo Assistant 2.

Analogue output connection

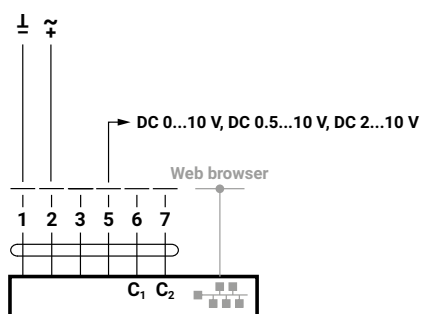

Connections BACnet, Modbus, MP-Bus

BACnet/IP or Modbus TCP

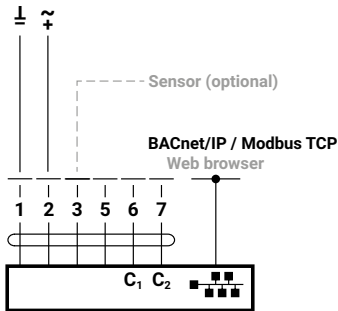

BACnet/IP or Modbus TCP with analogue output

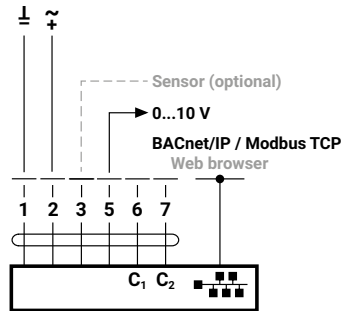

PoE with BACnet/IP or Modbus TCP

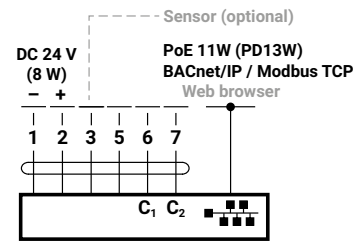

PoE with BACnet/IP or Modbus TCP with analogue output

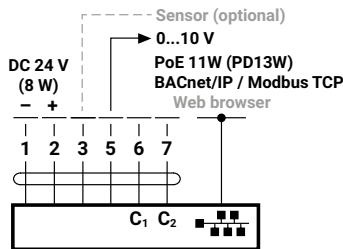

BACnet MS/TP or Modbus RTU

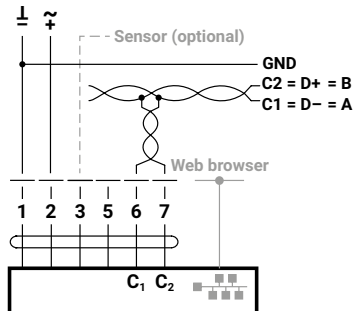

BACnet MS/TP or Modbus RTU with analogue output

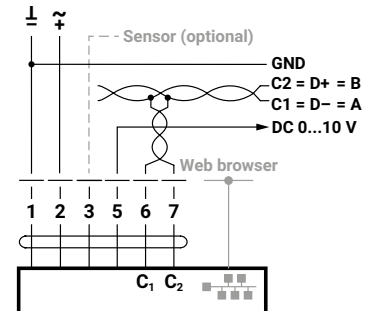

Wiring BACnet MS/TP or Modbus RTU (Daisy Chain)

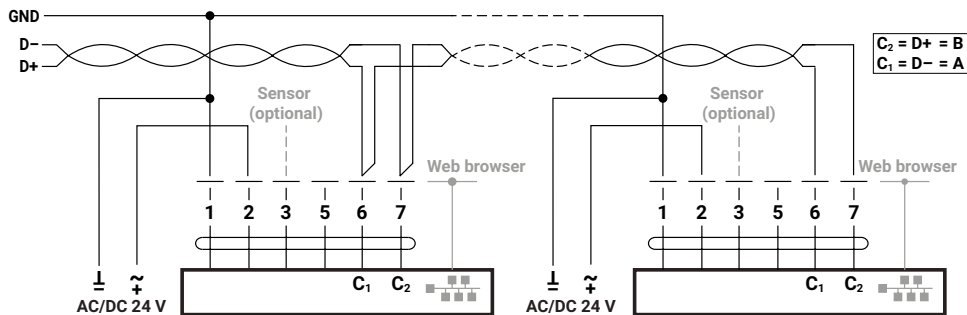

MP-Bus, supply via 3-wire

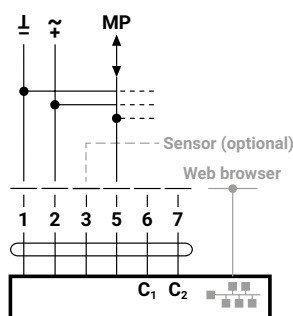

MP-Bus via 2-wire local power supply

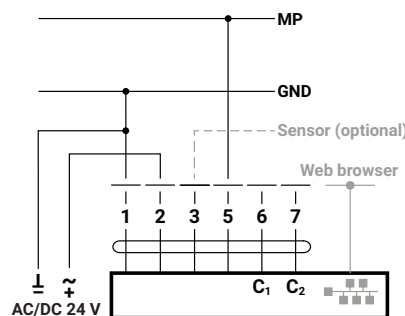

Connection of external sensors/switches (optional)

Passive sensor connection

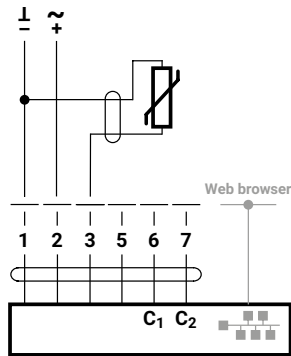

Switch connection

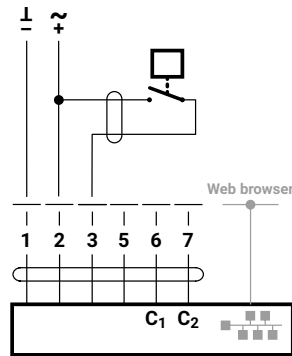

Active sensor connection

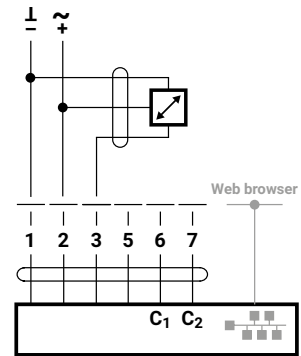

Connection to M-Bus via M-Bus converter G-22PEM-A01

M-Bus via M-Bus converter

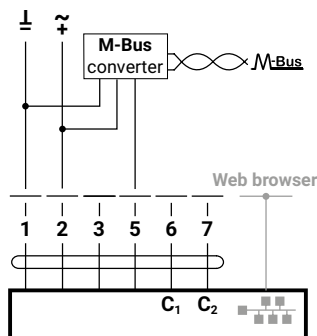

M-Bus parallel Modbus RTU or BACnet MS/TP

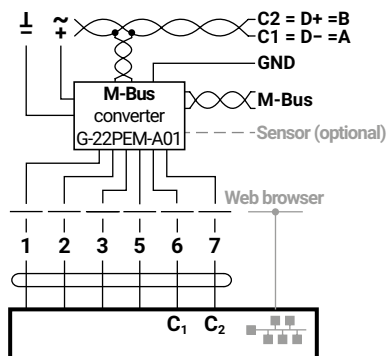

M-Bus parallel Modbus TCP or BACnet/IP

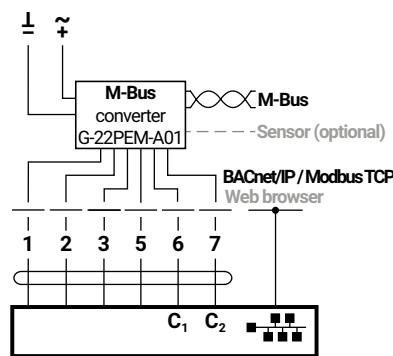



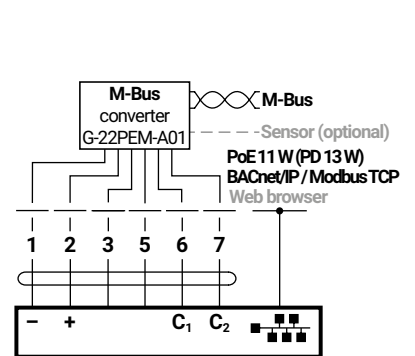





M-Bus parallel Modbus TCP or BACnet/IP with PoE



Activation of the thermal energy meter

Display symbols

Symbol	Meaning
	Flow is signalled
	Energy meter is installed in the supply
	Energy meter is installed in the return
	Energy meter already activated
	Energy meter not yet activated
	Cooling quantity is displayed
	Error present Note: details can be queried in the diagnostic loop
	Diagnostic loop is active
	Findings check mode active

Notes on activation



Notes on smartphones with Bluetooth

To successfully commission the thermal energy meter, it is necessary to set system-specific parameters using the Belimo Assistant 2. Communication from the smartphone to the thermal energy meter takes place via NFC (Near Field Communication). The settings made are then shown on the display of the thermal energy meter for verification and must be confirmed by pressing a button on the device to activate it. Once activated, the thermal energy meter will begin to accumulate the measured energy. The correct parametrisation of the thermal energy meter is a prerequisite for correct functioning.

The parameters can be set **once** and cannot be changed after activation.

Important:

- Activation is carried out only once and is irreversible, i.e. it is important to be attentive and mindful during activation. If activated incorrectly, the device will measure incorrectly and must be removed and replaced at the user's own expense.
- Whoever carries out commissioning is obliged to check all relevant parameters.
- A Belimo Cloud account is required for activation. Registration for a Belimo Cloud account can be completed at www.cloud.belimo.com. In addition, a credential is required, which can be obtained by completing an online learning module. The online learning module is available on a special website at www.belimo.ch/tem-activation.

The following chapter describes how to activate the thermal energy meter using the Belimo Assistant 2.

Bluetooth-enabled smartphones can be connected to the thermal energy meter via "Bluetooth-NFC converter" ZIP-BT-NFC (see chapter "NFC connection" in the "General notes").

Procedure for activation

Step 1

Connect the thermal energy meter to AC or DC 24 V or PoE (Power over Ethernet). Wait for the boot process until the status LED starts flashing.

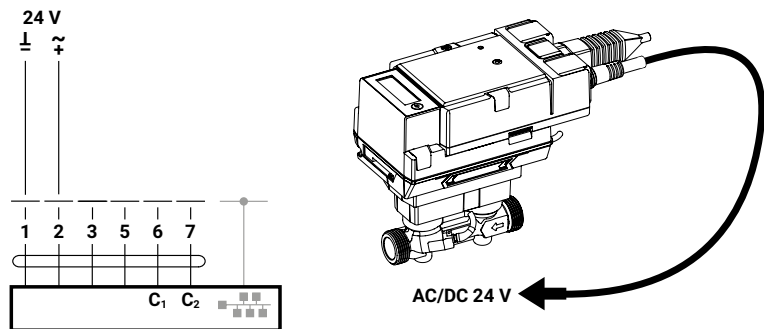

Step 2

Scan the thermal energy meter via NFC and read out data. The activation process can now be started via the overview page.

Initial situation:

- Status ok
- Energy meter not activated

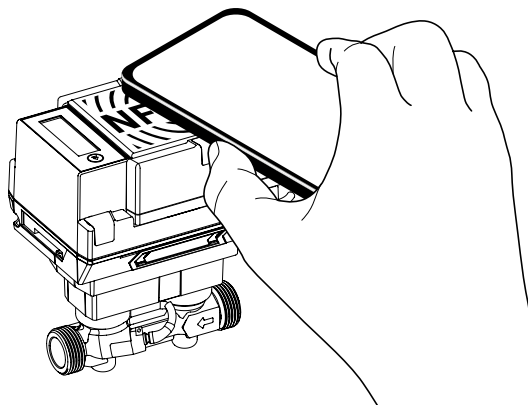

Step 3

Log in with Belimo Cloud Account ID

Step 4

Select the application according to system design

- a) Heating
- b) Cooling
- c) Heating and cooling

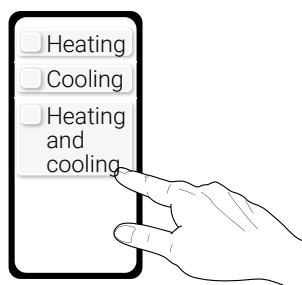

The thermal energy meter is not approved as a cooling meter (cooling application). Therefore, it is not legally compliant to use the thermal energy meter in legal trade as a cooling meter. Use as a cooling meter within the company is possible at any time.

Step 5

Select parameters for the corresponding application:

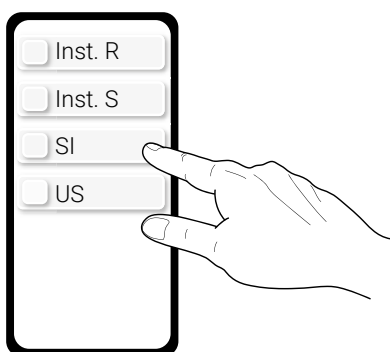
Heating

- Choice of installation in return (R) or in supply (S)
- The system of units must be selected
(SI = International System of Units, US = US System of Units)

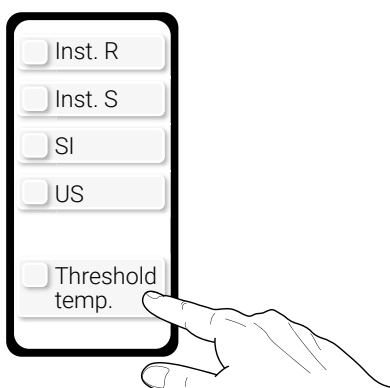
Cooling**Heating / cooling**

- Choice of installation in return (R) or in supply (S)
- The system of units must be selected
(SI = International System of Units, US = US System of Units)
- Advanced setting: the threshold temperature can be set as an option
(Threshold temp.)

Note on threshold temperature:

The threshold temperature is the temperature that is decisive for automatic switching between heating and cooling registers. The factory setting of 20°C is used for all applications, i. e. for heating, cooling or heating/cooling.

It is adjustable from 0...50°C for cooling as well as combined heating and cooling. This is fixed at the time of activation and, like the settings relating to the installation location and system of units, **cannot be changed afterwards.**

The value should only be changed if a very high supply temperature is selected for a cooling application. National regulations on how to set the threshold temperature may apply. According to standard EN 1434, the threshold temperature should be 3°C above the highest supply temperature in cooling mode and 3°C below the lowest supply temperature in heating mode.

The threshold temperature cannot be deactivated due to legal requirements for billing purposes, particularly for combined heating and cooling operation.

Graphical representation

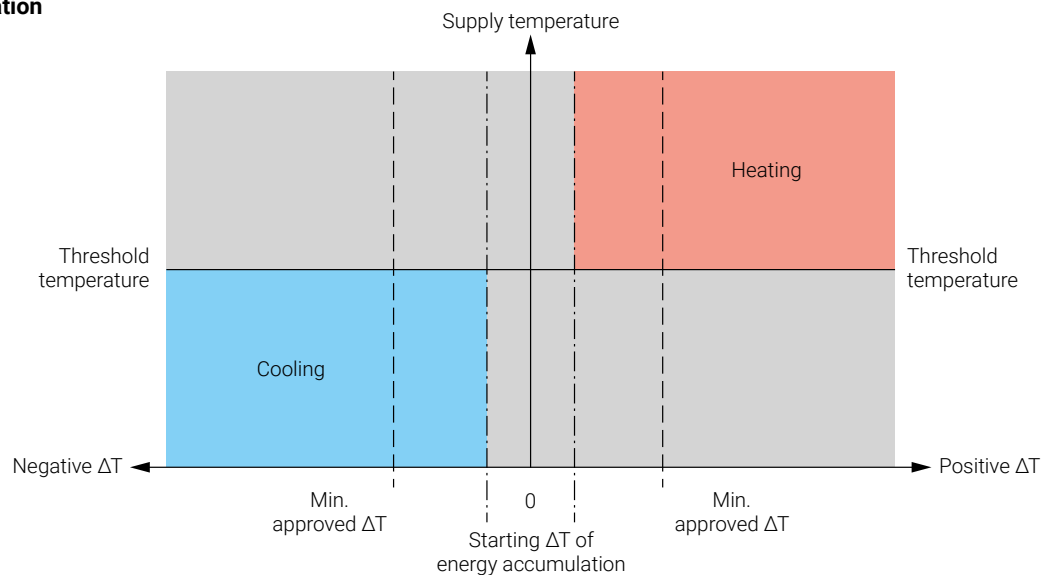

Definition of heating/cooling with threshold temperature and differential temperatures (ΔT) according to EN 1434

Based on this, entries are made in the heating or cooling register under the following conditions:

Energy recording in heating register if:

- measured $\Delta T >$ starting ΔT for energy accumulation and
- supply temperature $>$ threshold temperature

Energy recording in cooling register if:

- measured $\Delta T <$ starting ΔT for energy accumulation and
- supply temperature $<$ threshold temperature

Note: The minimum approved differential temperature of the thermal energy meter according to the type approval must be considered when designing the system. Above this, compliance with the permissible errors according to the type approval is guaranteed. See datasheet of the thermal energy meter. Energy accumulation starts at starting ΔT of 0.5 K.

Step 6

Transfer values to the thermal energy meter via NFC

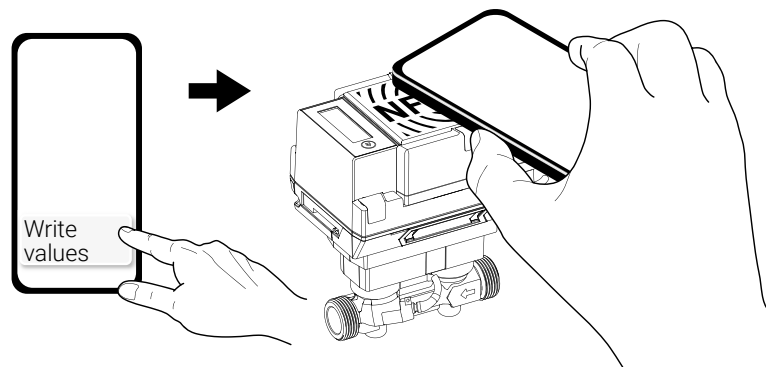

Step 7

The parameters selected in step 5 are now visible on the smartphone. At the same time, the "commissioning loop" is initiated on the display of the thermal energy meter. The display views are automatically changed in ascending order with an interval of 2.5 s. Once the last display view is reached, the first one is displayed again. **Whoever carries out commissioning is obliged to check all relevant parameters.** If all parameters are correct,

they must be confirmed by pressing the display button on the thermal energy meter (>2 s) within 5 minutes. **Note:** if the key is not pressed, the app will display the message "Values not written". In this case, activation must be restarted. After a time-out of 5 minutes, the "commissioning loop" is terminated and the commissioning process aborted.

Heating

Loop during 5 minutes

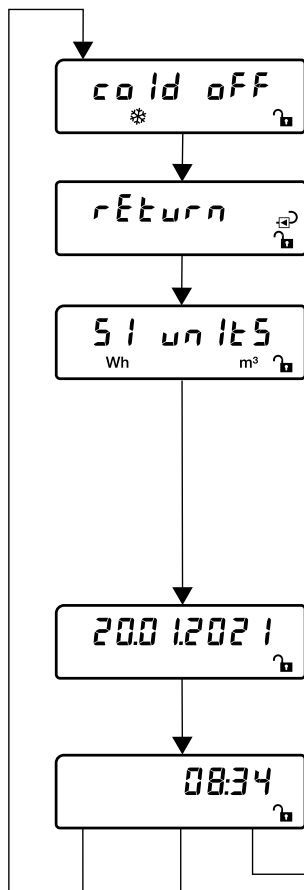

Cooling quantity:

Indication of whether the cooling quantity is shown on the display. For heating applications, the cooling register is switched off and for cooling applications it is switched on.

Installation of the energy meter:

Indication of whether the thermal energy meter is in supply or return
 ↻ R = return ↻ S = supply

System of units:

Indication of whether the system of units of the thermal energy meter is set to SI or US. According to the European Measuring Instruments Directive (MID), the energy meter must be set to SI units.

Threshold temperature:

The threshold temperature is displayed, which is decisive for automatic switchover between heating and cooling register.

Display view, date:

Current date display formatted as DD.MM.YYYY

Display view, current time:

The current time is displayed (range 00:00...23:59) regardless of the set system of units. The thermal energy meter automatically adopts the time and date of the smartphone.

Cooling Heating / cooling

Loop during 5 minutes

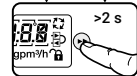
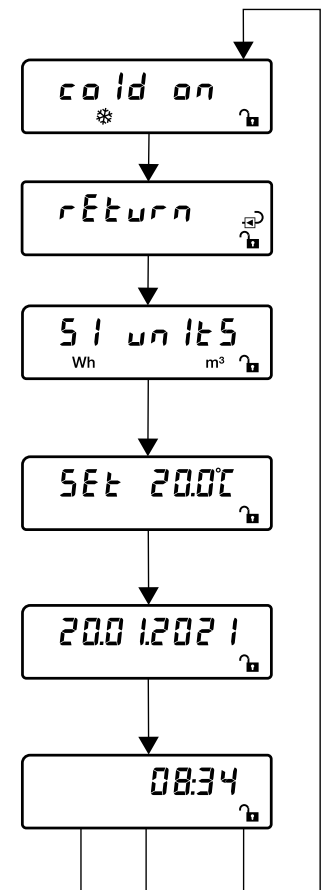

If the button is not pressed within 5 minutes

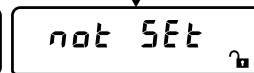
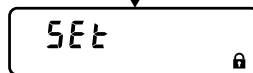

Result of commissioning

After pressing the display button, the display shows whether the activation of the energy meter was successful. SEt = successful, not SEt = not successful

Step 8

Scan thermal energy meter via NFC:

- Message appears: thermal energy meter successfully activated!

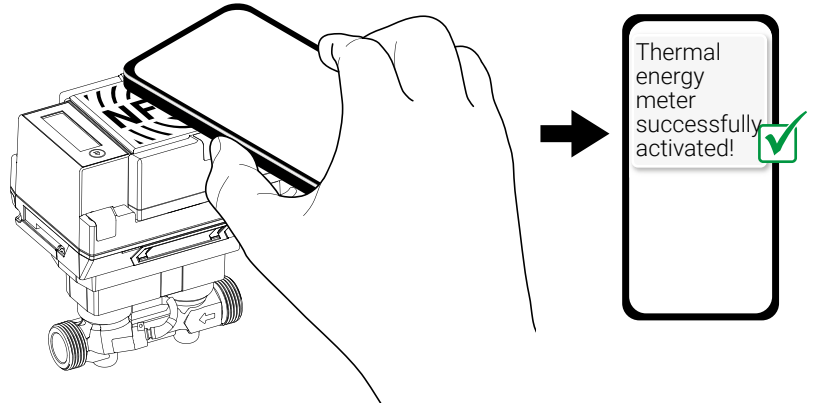
**Commissioning protocol**

To prevent installation errors, it is recommended to have an installation and commissioning protocol issued when the thermal energy meter is installed or replaced. Documenting all measuring point data, meter data, the installation situation and the operating states ensures that the correct installation and the function of the thermal energy meter can reliably be verified. As a result, the legal certainty of subsequent auxiliary cost statements can be additionally substantiated and tenant objections can be invalidated.

The commissioning protocol of the thermal energy meter is based on the submission of the technical guideline K9 of the German Physikalisch-Technische Bundesanstalt (PTB). After commissioning the thermal energy meter, the commissioning protocol is saved on the device owner's Belimo Cloud account. The commissioning protocol can also be created at a later date. In this case, please note that the current meter data are used, which might differ from the data at legal commissioning/activation.

Display loops

User loop

The "user loop" is started by activating the dark LCD display by briefly pressing (<2 s) the display button. It may take a moment for display view 1 to appear. During this time, "Hold on" is displayed. The view can be changed in ascending order by briefly pressing the display button. When the last entry in the

table is reached, the first entry is displayed again. The "user loop" is exited after a timeout of 30 s. The timeout is restarted each time the display button is pressed. After a timeout, the display is switched off.

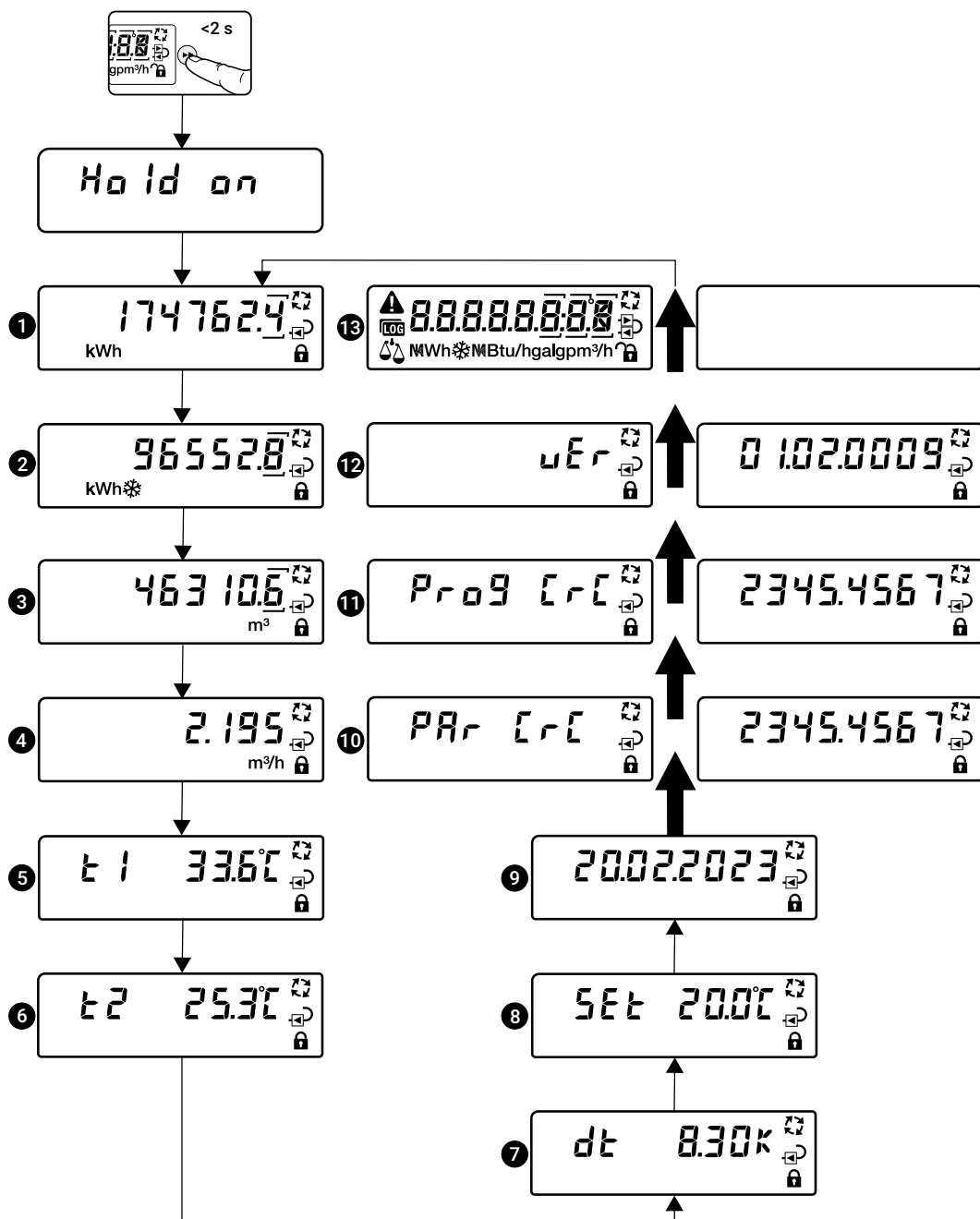

Description of the display views "User loop"

If there are error messages, the display below appears. The errors are displayed in ascending order (... = error code 00...99). In the other display views 1...11 of the user loop, a warning triangle is displayed. If there are no errors, this display does not appear.



1	Accumulated heat quantity	The current accumulated heat quantity is displayed. If there is a permanent error (error codes 1...16), the last permanently stored accumulated heat quantity is displayed.
2	Accumulated cooling quantity	The current accumulated cooling quantity is displayed. If there is a permanent error (error codes 1...16), the last permanently stored accumulated cooling quantity is displayed. This display does not appear for pure heating applications.
3	Accumulated volume	The current accumulated volume is displayed. If there is a permanent error (error codes 1...16), the last permanently stored accumulated volume is displayed.
4	Current flow	The current flow is displayed.
5	Current temperature of external temperature sensor T1	The current temperature of the external temperature sensor is displayed.
6	Current temperature of the temperature sensor T2 integrated in the thermal energy meter	The current temperature of the temperature sensor integrated in the thermal energy meter is displayed.
7	Differential temperature	The current differential temperature between supply and return is displayed.
8	Threshold temperature	The threshold temperature is displayed, which is decisive for automatic switchover between heating and cooling register.
9	Date	Current date display formatted as DD.MM.YYYY
10	CRC type-specific parameter	For display purposes, the two display views are alternately displayed at 1-s intervals. The CRC code is used to indicate that the factory settings have not been changed.
11	CRC program code	For display purposes, the two display views are alternately displayed at 1-s intervals. The CRC code is used to indicate that the program code has not been changed.
12	Software version	For display purposes, the two display views are alternately displayed at 1-s intervals.
13	LCD test	The LCD display is being tested. In 1-s intervals, all characters are displayed and then deleted again. During this process, you can check that all characters and symbols are shown on the display.

To save the battery, the LCD display is deactivated when the battery voltage is critical. In this case, the display below appears. The measuring operation continues nevertheless. To reactivate the display, the thermal energy meter must be supplied with external voltage. This should be done promptly after the battery warning occurs to prevent the battery voltage from dropping further below a critical value, which would result in persistent error 08.

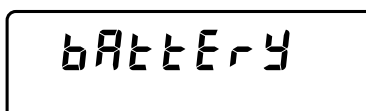

Diagnostic loop

The "diagnostic loop" is started from the "user loop" by pressing the display key (>2 s) and indicated by the symbol . You can switch from the "user loop" to the "diagnostic loop" and back by pressing and holding the display key (>2 s). The display view can be changed in ascending order by briefly pressing the display

key. After the last display is reached, the first display is shown again. The "diagnostic loop" is exited after a timeout of 30 s. The timeout is restarted each time the display button is pressed. After a timeout, the display is switched off.

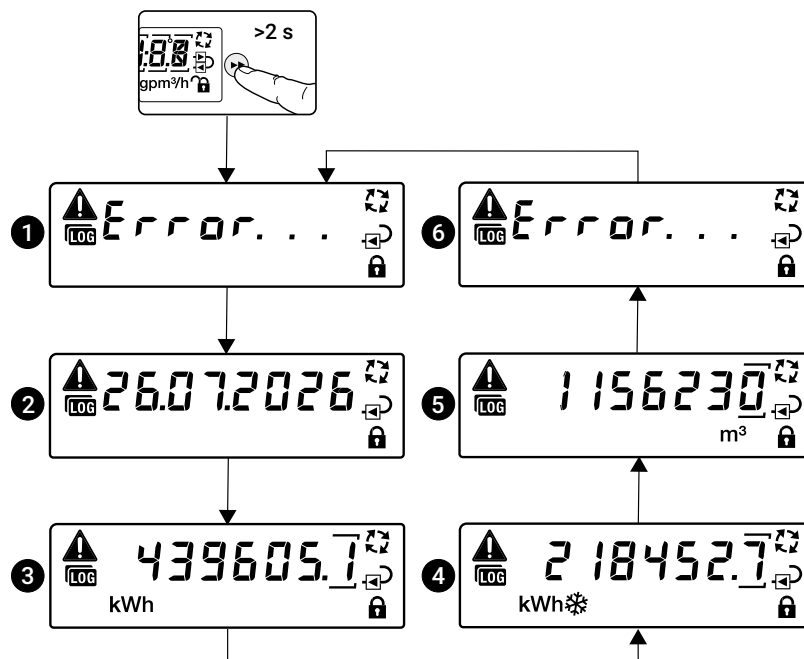

Description of display views "Diagnostic loop"

If no messages are pending, the following display appears:

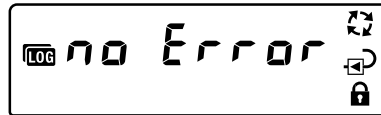

1	Error number (... = error code 00...99)	The error with the lowest error number is displayed (permanent errors have lower error numbers).
2	Date	The date of the last permanently stored meter readings is displayed.
3	Accumulated heat quantity	The last permanently stored accumulated heat quantity is displayed.
4	Accumulated cooling quantity	The last permanently stored accumulated cooling quantity is displayed. Is only displayed if the cooling quantities are activated.
5	Accumulated volume	The last permanently stored volume is displayed.
6	Other errors (... = error code 00...99)	Additional error codes are displayed.

Error codes

Permanent errors

Error code	Meaning
Err 01	Temperature sensor T2 (temperature sensor integrated in the sensor module) is short-circuited. This has been detected in several successive measurements (only released after legal commissioning of the device)
Err 02	Temperature sensor T2 (temperature sensor integrated in the sensor module) is interrupted. This has been detected in several successive measurements (only released after legal commissioning of the device)
Err 03	Temperature sensor T1 (external temperature sensor) is short-circuited. This has been detected in several successive measurements (only released after legal commissioning of the device)
Err 04	Temperature sensor T1 (external temperature sensor) is interrupted. This has been detected in several successive measurements (only released after legal commissioning of the device)
Err 05	Permanent communication error with non-volatile memory (SPI)
Err 06	Program code integrity check failed
Err 07	Parameter integrity check failed
Err 08	Complete power failure detected, i.e. neither external nor battery power supply was available. Only for MID devices after activation/ legal commissioning (protection against fraud)
Err 09	The data format in the non-volatile memory does not match the data format in the sensor uC software
Err 10	Integrity check of data in non-volatile memory failed
Err 11	An error counter has reached the maximum value
Err 12	
Err 13	
Err 14	
Err 15	
Err 16	

Temporary errors

Error code	Meaning
Err 17	
Err 18	The ultrasonic path is interrupted (air bubbles in the system, connection to ultrasonic transducers interrupted)
Err 19	Ultrasonic time of flight out of range
Err 20	Automatic gain controller out of range (problem with the ultrasonic transducer or wrong fluid)
Err 21	
Err 22	Volume accumulation failed
Err 23	Heat/cold accumulation failed
Err 24	The raw resistance measurement of temperature sensor T1 (external temperature sensor) or temperature sensor T2 (temperature sensor integrated in the sensor module) is invalid
Err 25	Calculation error
Err 26	Temperature sensor T2 (temperature sensor integrated in the sensor module) is short circuited
Err 27	Temperature sensor T2 (temperature sensor integrated in the sensor module) is interrupted
Err 28	Temperature sensor T1 (external temperature sensor) is short circuited
Err 29	Temperature sensor T1 (external temperature sensor) is interrupted
Err 30	Flow in reverse direction (backflow) detected
Err 31	Flow above the upper limit value
Err 32	Invalid flow

Sealing and security sealing

Factory-applied seals

The following seals are applied at the factory.

Seal 1

Seal (1) visualises manipulations of the internal temperature sensor T2.

Seal 2

Seal (2) visualises manipulations of the sensor module (calculator unit).

Seal 3

Seal (3) visualises manipulations of the logic module.

Note:

If the sensor module is purchased as a spare part, a seal (3) is included. The authorised person who replaces the sensor module must reapply the seal (3) after work has been carried out.



The factory seals (1) and (2) of the thermal energy meter must not be changed, damaged or removed – otherwise the guarantee and MID conformity of the device are void.

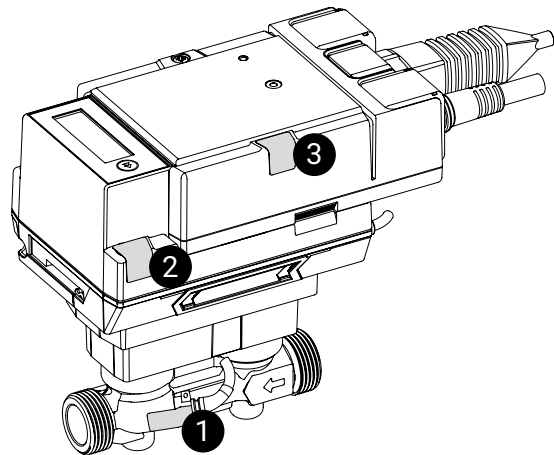

Security sealing on the system

After the thermal energy meter has been installed and commissioned, it must be fitted with security seals by an authorised person (security seals in the scope of delivery) and the seals attached at the factory must be checked to ensure they are intact.

Security seal 4

Security seal (4) visualises manipulations of the external temperature measuring point (security sealing of the temperature measuring ball valve).

Security seal 5

Security seal (5) visualises manipulations of the measured section of the thermal energy meter (security sealing between open/close valve and flow sensor body).

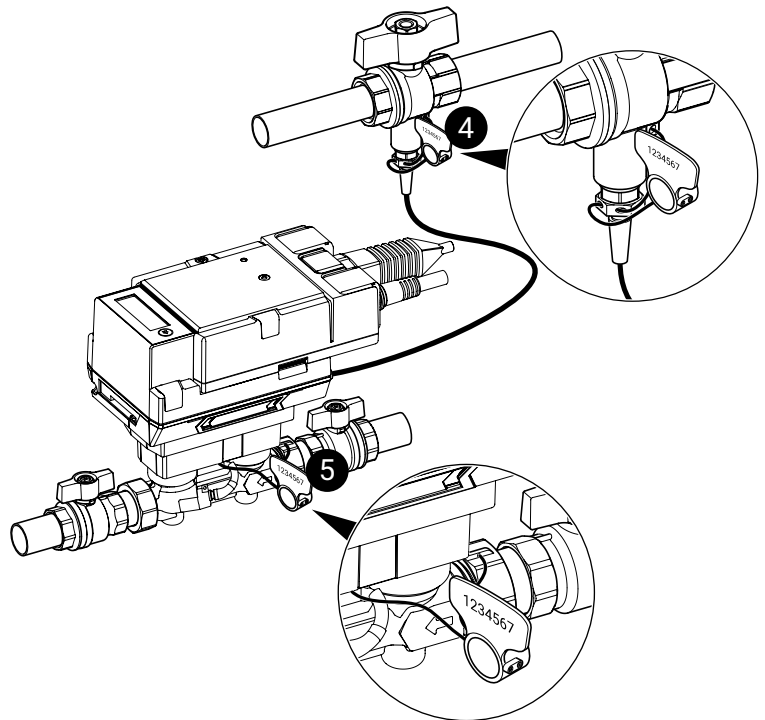

Properly affixing security seals

- a) Thread the seal wire through all the openings provided for this purpose in the temperature measurement point and the security seal
- b) Turn the handle of the security seal clockwise until the seal is flush with the surface and secured

Security seal 4

Security sealing of the ball valve with measuring port

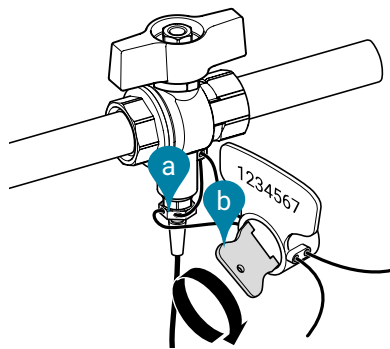

- c) Cut seal wires with side cutter directly on the security seal

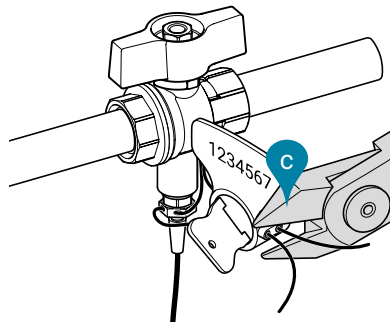

- d) Move the handle of the security seal back and forth until it falls off
- e) Handle of the security seal drops off, security seal is secured
- f) Dispose of the handle of the security seal

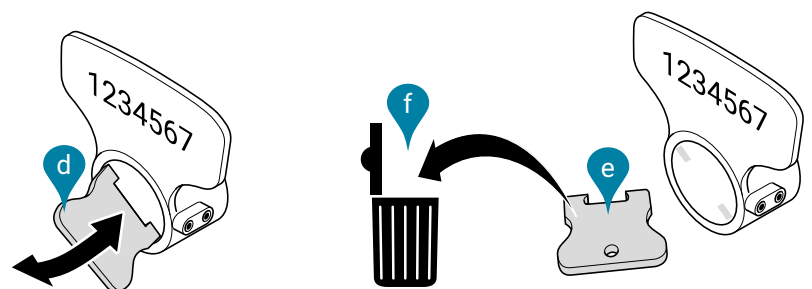

- g) Record the consecutive and unique 7-digit number of security seals (4) and (5) and transfer the number to the commissioning protocol

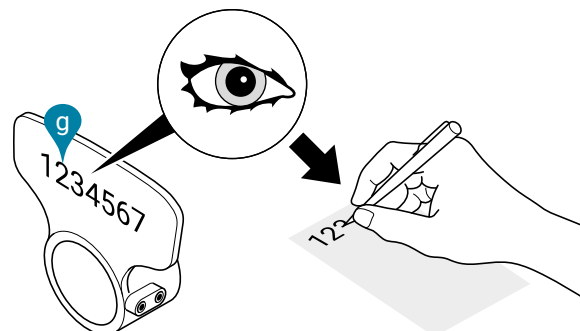

Exchanging the sensor module

Logic module of the thermal energy meter

The thermal energy meter is supplied with voltage via the logic module. The bus and NFC communication interface is also available on the logic module. If the sensor module is disconnected from the logic module for replacement, the connecting cables can remain connected to the logic module and the system.

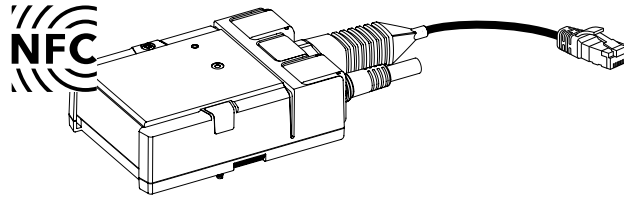

Sensor module of the thermal energy meter

The sensor module contains the integrated temperature sensor T2 and the external temperature sensor T1 is connected via a cable. If the sensor module is replaced, both temperature sensors T1 and T2 must also be replaced. The sensor module also houses the calculator unit and the ultrasonic flow measurement system.



In certain countries, the sensor module must be replaced periodically for recalibration and is therefore available as a spare part. Relevant national regulations must be observed. After expiry of the national recalibration period, the use of the thermal energy meter is no longer legally compliant.

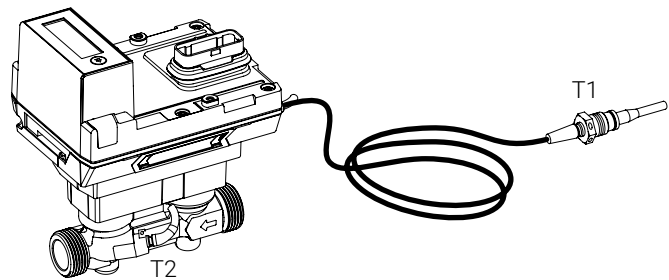

Separate the logic module and sensor module

- a) Remove security seals and close the ball valve with measuring port and the open/close valves
- b) Remove seal (3)
- c) Loosen the screws of the logic module
- d) Separate the logic module and sensor module
- e) Loosen brass screw connection of temperature sensor T1 and pull out sensor
- f) Loosen the screw connections on the sensor module and remove the sensor module

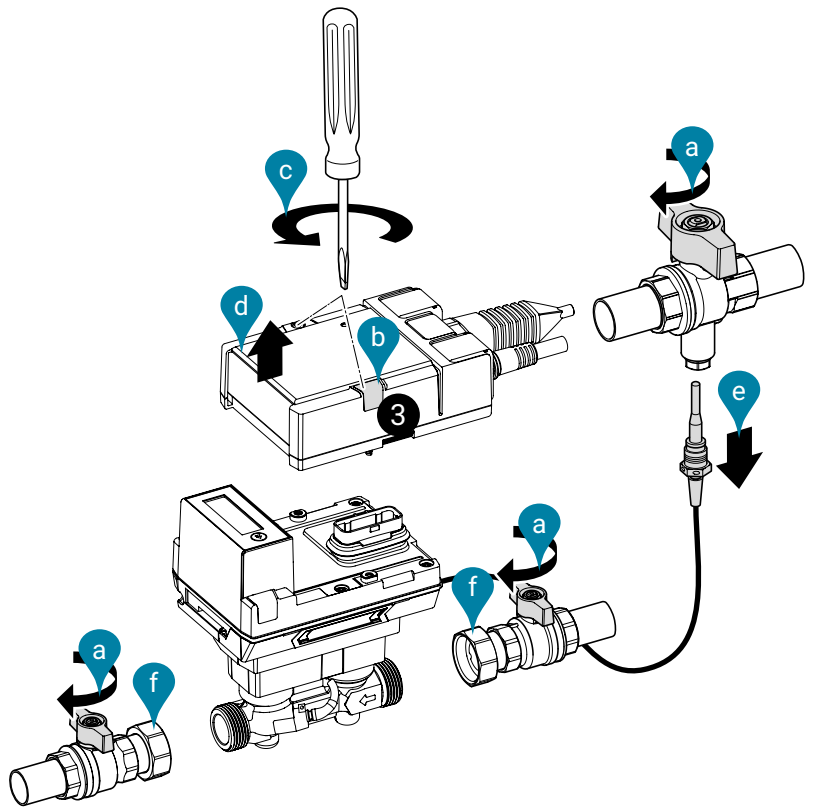

Sensor module as a spare part

Product type from Belimo	DN	DN (°)	G (°)
R-22PEM-0UC	15	1/2	3/4
R-22PEM-0UD	20	3/4	1
R-22PEM-0UE	25	1	1 1/4
R-22PEM-0UF	32	1 1/4	1 1/2
R-22PEM-0UG	40	1 1/2	2
R-22PEM-0UH	50	2	2 1/2

Comprising:

- Sensor module including the integrated temperature sensor T2 and the external temperature sensor T1

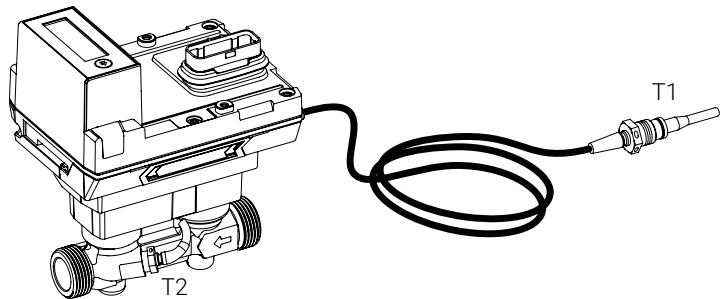

- 2 security seals consecutively numbered (unique number) with attached wire approx. 40 cm

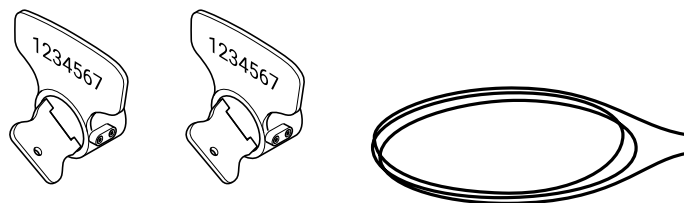

- 1 seal (seal 3)

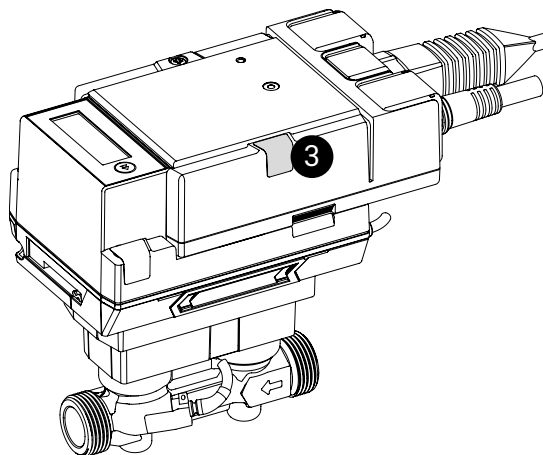

Accessories

Optional accessories

- MID accessory kits optionally with or without fitting piece consisting of:
- 2x open/close valves with internal thread and union nut (installation of thermal energy meters)
 - 1x ball valve with measuring port, sealable (sensor installation directly immersed)
 - 1x open/close valve single

MID accessory kit without fitting piece

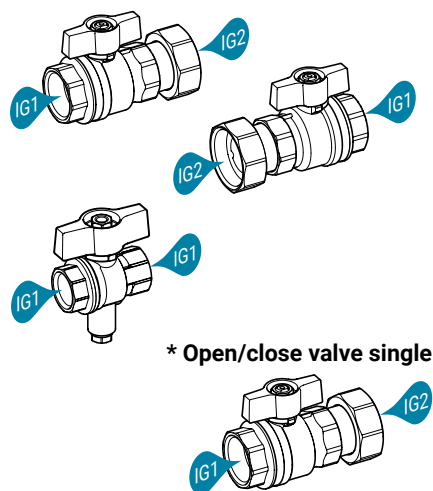

Energy meter (DN)	Internal thread 1 (IG1)	Internal thread 2 (IG2)	Product type from Belimo	Open/close valve single
	Open/close valve (Rp)	Open/close valve (G)		Product type from Belimo
15	1/2"	3/4"	EXT-EF-15A	EXT-EF-15G
20	3/4"	1"	EXT-EF-20A	EXT-EF-20G
25	1"	1 1/4"	EXT-EF-25A	EXT-EF-25G
32	1 1/4"	1 1/2"	EXT-EF-32A	EXT-EF-32G
40	1 1/2"	2"	EXT-EF-40A	EXT-EF-40G
50	2"	2 1/2"	EXT-EF-50A	EXT-EF-50G

MID accessory kit with fitting piece

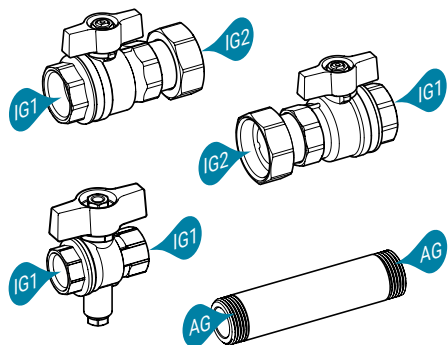

Energy meter (DN)	Internal thread 1 (IG1)	Internal thread 2 (IG2)	Fitting piece (AG)	Fitting piece length (mm)	Product type from Belimo
	Open/close valve (Rp)	Open/close valve (G)	External thread (G)		
15	1/2"	3/4"	3/4"	110	EXT-EF-15B
20	3/4"	1"	1"	130	EXT-EF-20B
25	1"	1 1/4"	1 1/4"	135	EXT-EF-25B
32	1 1/4"	1 1/2"	1 1/2"	140	EXT-EF-32B
40	1 1/2"	2"	2"	145	EXT-EF-40B
50	2"	2 1/2"	2 1/2"	145	EXT-EF-50B

	Product type from Belimo	For DN
Insulation shell		
For thermal insulation of the thermal energy meter	A-22PEM-A01	15, 20, 25
	A-22PEM-A02	32, 40, 50
Security seals		
2 pieces consecutively numbered (unique number) with attached wire	A-22PEM-A03	
Silicone grommet with clamp	A-22PEM-A04	
M-Bus converter	G-22PEM-A01	
Bluetooth-NFC converter	ZIP-BT-NFC	

All inclusive.

Belimo is the global market leader in the development, production, and sales of field devices for the energy-efficient control of heating, ventilation and air-conditioning systems. The focus of our core business is on damper actuators, control valves, sensors and meters.

Always focusing on customer value, we deliver more than only products. We offer you the complete product range for the regulation and control of HVAC systems from a single source. At the same time, we rely on tested Swiss quality with a five-year warranty. Our worldwide representatives in over 80 countries guarantee short delivery times and comprehensive support through the entire product life. Belimo does indeed include everything.

The "small" Belimo devices have a big impact on comfort, energy efficiency, safety, installation and maintenance.

In short: Small devices, big impact.



5-year warranty



On site around the globe



Complete product range



Tested quality



Short delivery times



Comprehensive support